



**CATALOGUE
FOR
RJK CONE WINDING MACHINE PARTS**

**INSTRUCTION FOR INSTALLATION
&
MAINTENANCE**



BASE ASSEMBLY

RJK

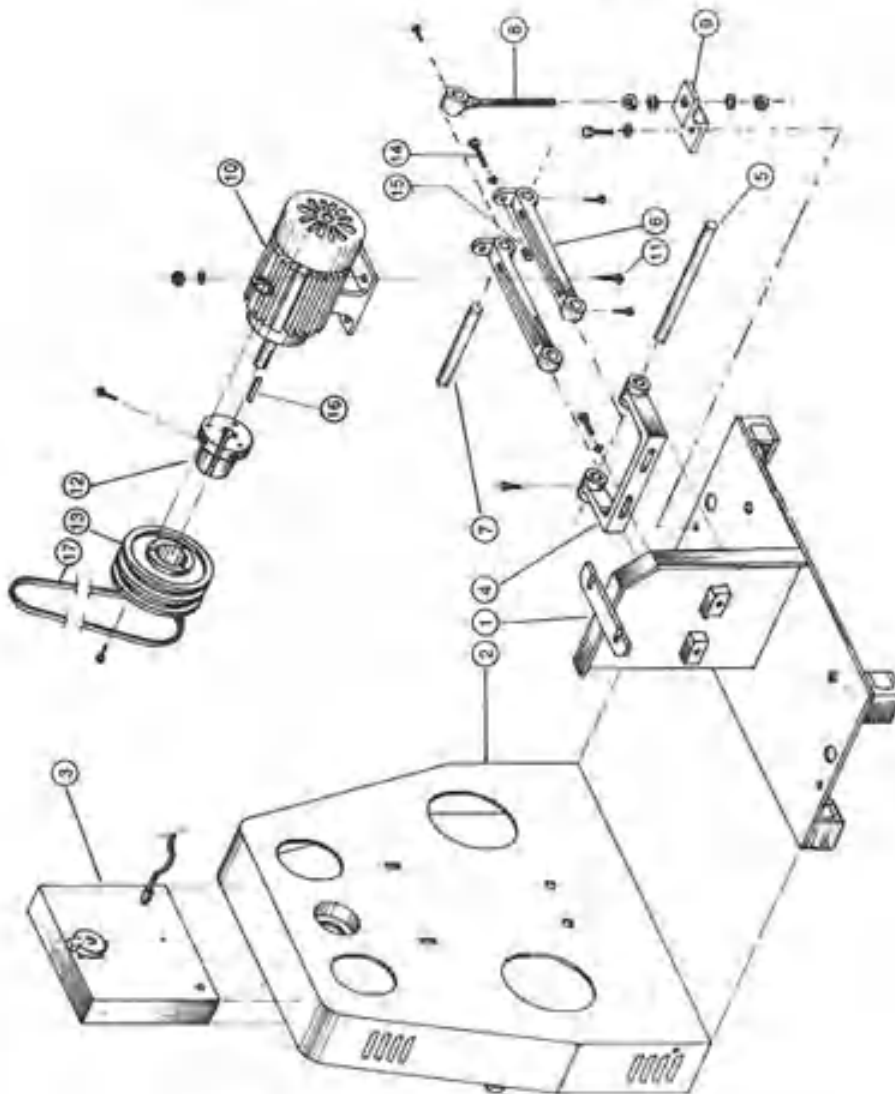

- (1) Base
- (2) Electric Panel Box (Big)
- (3) Electric Panel Box (Small)
- (4) Motor Rail Bracket
- (5) MDR 125 Motor Rail Shaft
- (6) 71-115.4 Motor Rail
- (7) MDP 125 Motor Rail Shaft
- (8) MDP 126 Adjusting Bracket With SC. 2650 Adjusting Screw
- (9) MDP 127 Supporting Bracket

- (10) Main Drive Motor (5 HP)
- (11) Carriage Bolt
- (12) Taper Bush For Motor Pulley
- (13) Motor Pulley-450 YPM, 550YPM, 650 YPM, 750 YPM, 850 YPM.
- (14) MDP 176 Adjusting Pin
- (15) Motor Rail Knob
- (16) Key For Main Drive Motor
- (17) V. Belt B5B

RJK

RIBBON BREAKER ASSEMBLY

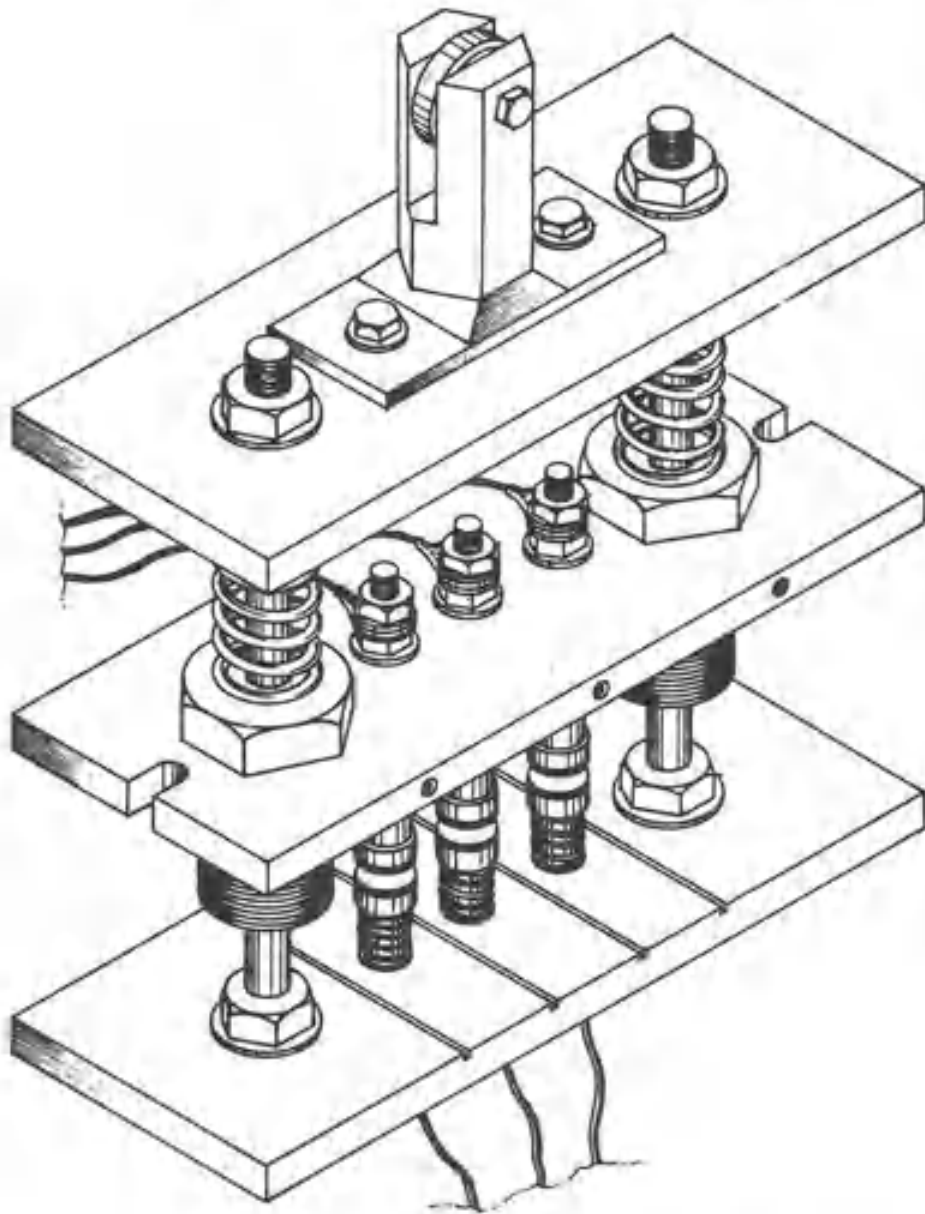

ANTI - PATTERNING DEVICE

(ES 156 Ribbon Breaker Assembly)

RIBBON BREAKER ASSEMBLY

RJK

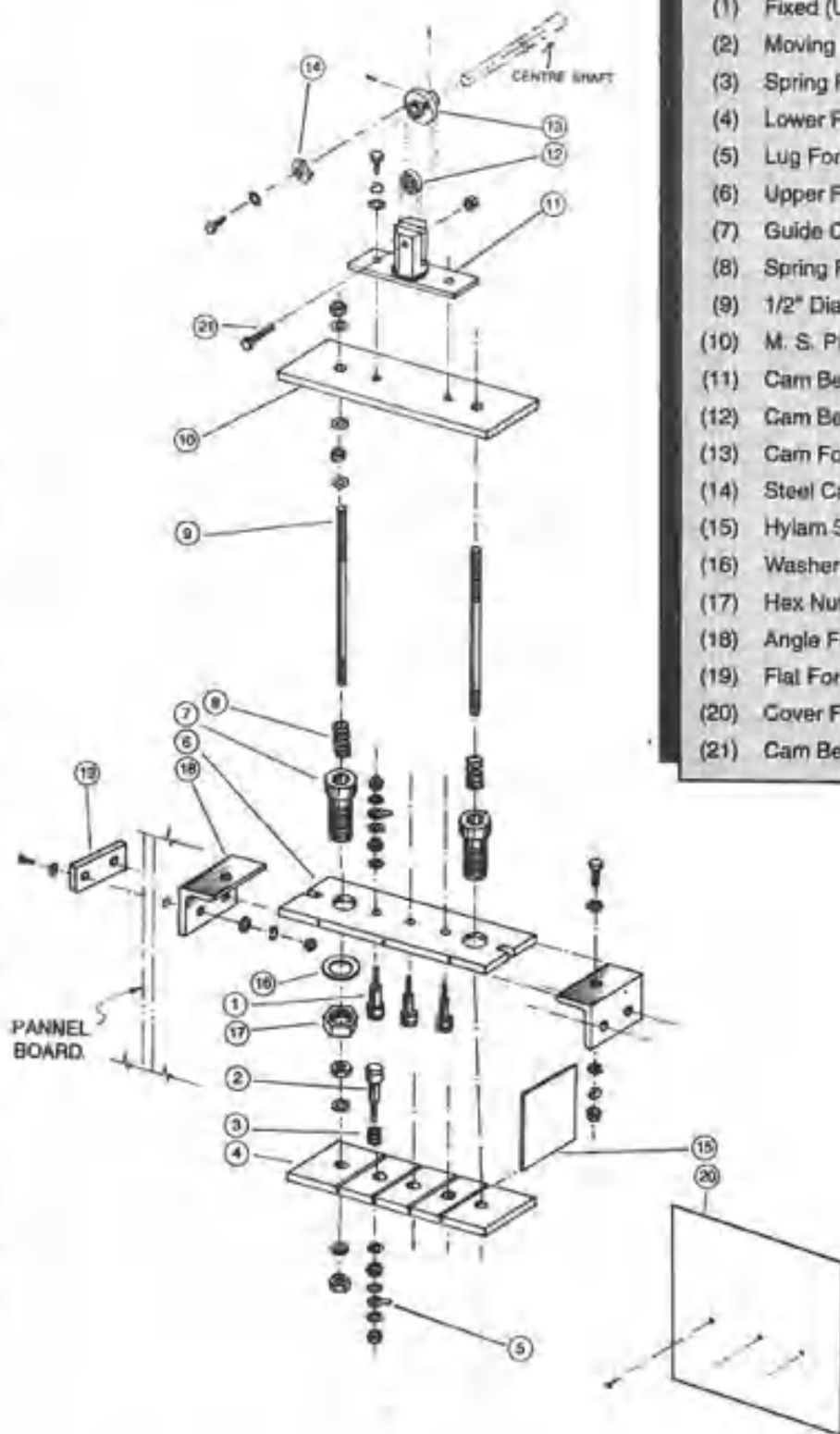

- (1) Fixed (Upper) Silver Contact
- (2) Moving (Lower) Silver Contact
- (3) Spring For Moving Contact
- (4) Lower Fiber plate
- (5) Lug For Contacts
- (6) Upper Fiber plate
- (7) Guide Collar For 1/2" Dia Stud
- (8) Spring For 1/2" Dia M. S. Stud
- (9) 1/2" Dia M. S. Stud
- (10) M. S. Plate Big
- (11) Cam Bearing Holder Bracket
- (12) Cam Bearing (R7-ZZ)
- (13) Cam For Contactor
- (14) Steel Cam Piece
- (15) Hylam Separator
- (16) Washer For Guide Collar
- (17) Hex Nut For Guide Collar
- (18) Angle For Foung Contactor
- (19) Flat For Fixing Contactor
- (20) Cover For Contactor
- (21) Cam Bearing Pin

RJK

GEAR BOX ASSEMBLY - 1

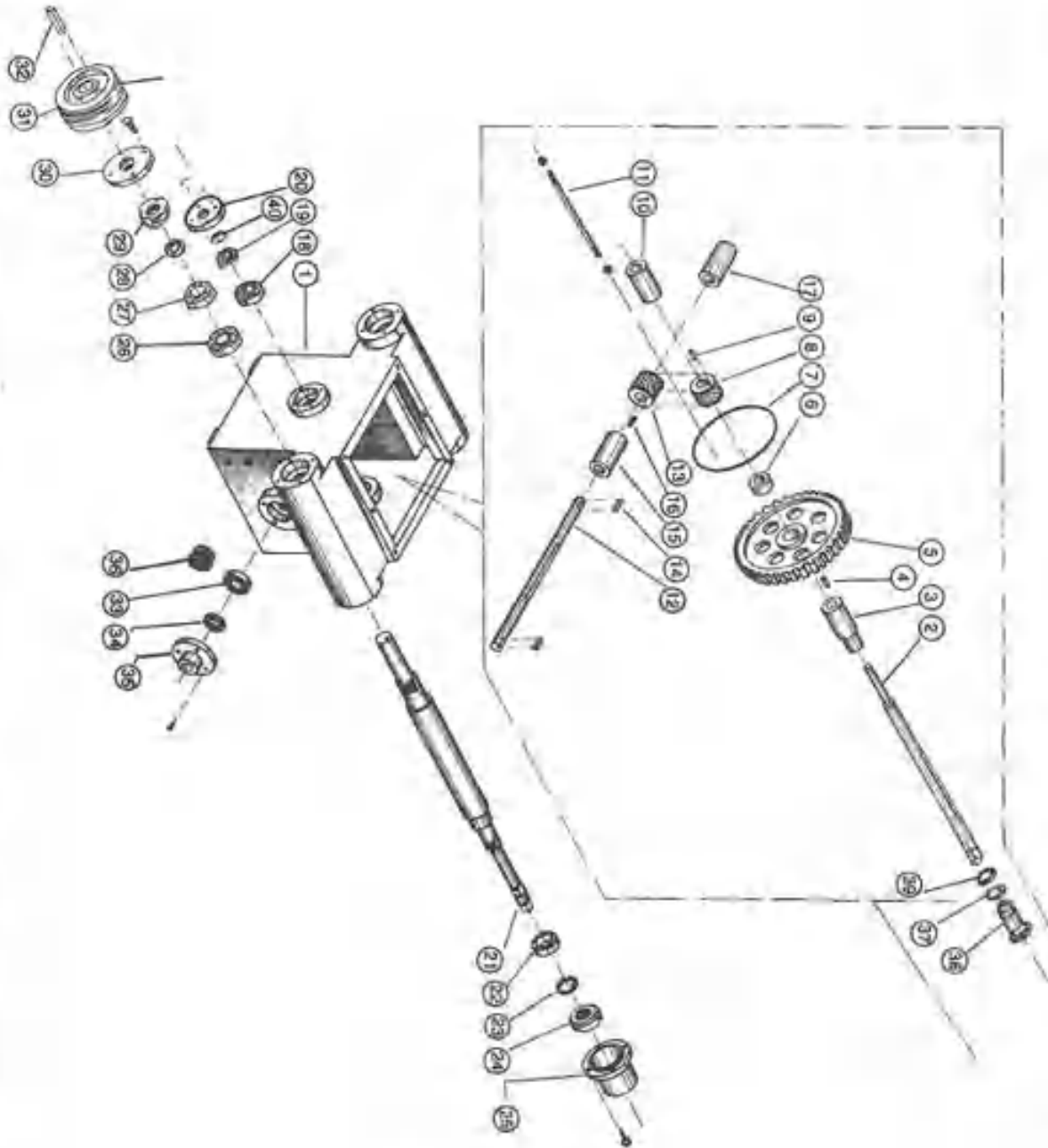

- (1) 71-103-20X Case
- (2) 71-67-3 Shaft
- (3) 71-310 Spacer
- (4) Key
- (5) 71-101-2 Gear 90T
- (6) Small Spacer
- (7) Oil Ring
- (8) 71-109-3X Spiral Gear 18T
- (9) Key
- (10) Spacer
- (11) 3/8" Dia Stud
- (12) 71-252-4 Shaft (For Conveyor)
- (13) 71-109-3X Spiral Gear 18T
- (14) Key
- (15) Spacer
- (16) Key
- (17) Spacer
- (18) Ball Bearing -LS10
- (19) G-Box Oil Seal (Big) For Conveyor
- (20) 71-60 4X Cap
- (21) 71-65-3 (Gear Box Drum Shaft)
- (22) Ball Bearing 6205 ZZ
- (23) 1302 Star Washer (Small)
- (24) Nut for Gear Box Drum Shaft (Small)
- (25) 71-61-6 Inner Cap
- (26,27) Ball Bearing 6207 ZZ
- (28) 1304 Star Washer (Big)
- (29) Nut for Gear Box Drum Shaft (Big)
- (30) 71-61-5 Bearing Cap
- (31) Traverse Pulley "B"
- (32) Key
- (33) Ball Bearing LS10
- (34) Oil Seal (Big)
- (35) Bearing Cover (for Conveyor Shaft)
- (36) Oil Indicator
- (37) 'O' Ring For Small Sleeve
- (38) 71-53XX Sleeve Small
- (39) Rubber Ring

GEAR BOX ASSEMBLY - 2

- (1) Reduction Motor Rest
- (2) ½ Hp Pilot Motor
- (3) Oil Seal 32-19-7 For Pilot Motor
- (4) Sleeve For Oil Seal
- (5) 71-120-2x 15T Fibre Pinion
- (6) Key
- (7) Gasket For 71-83-5x Gear Case
- (8) 71-66-2 Shaft
- (9) Collar
- (10) 71-100x Compound Gear 75 X 15T
- (11) Hex Nut
- (12) Key
- (13) Nut For Oil Gauge
- (14) Oil Gauge
- (15) Press Button Oiler
- (16) 71-83-5x Gear Case
- (17) Big Gasket For 71-103-20x Case

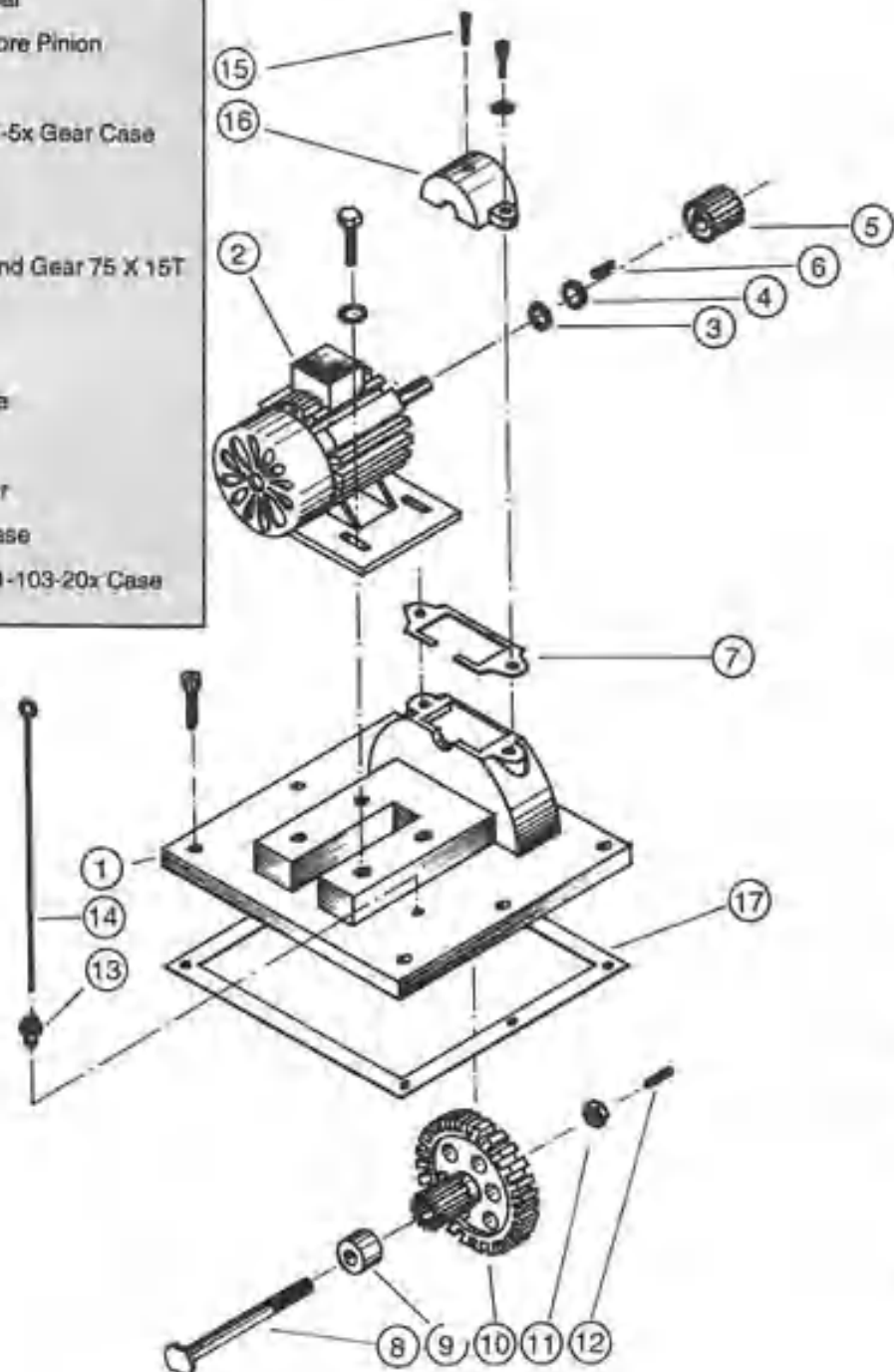

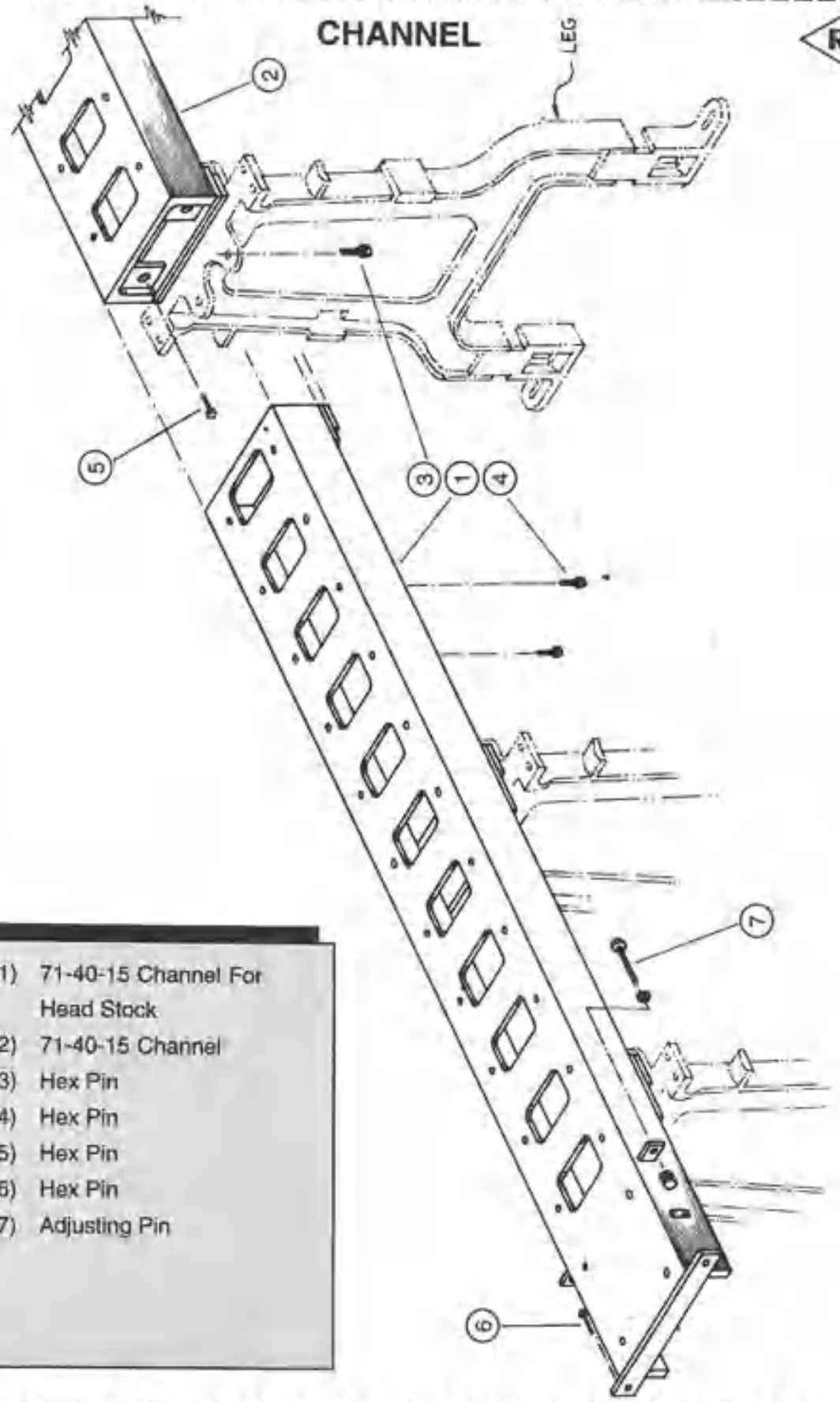

- (1) 71-40-15 Channel For Head Stock
- (2) 71-40-15 Channel
- (3) Hex Pin
- (4) Hex Pin
- (5) Hex Pin
- (6) Hex Pin
- (7) Adjusting Pin

RJK

LEG ASSEMBLY

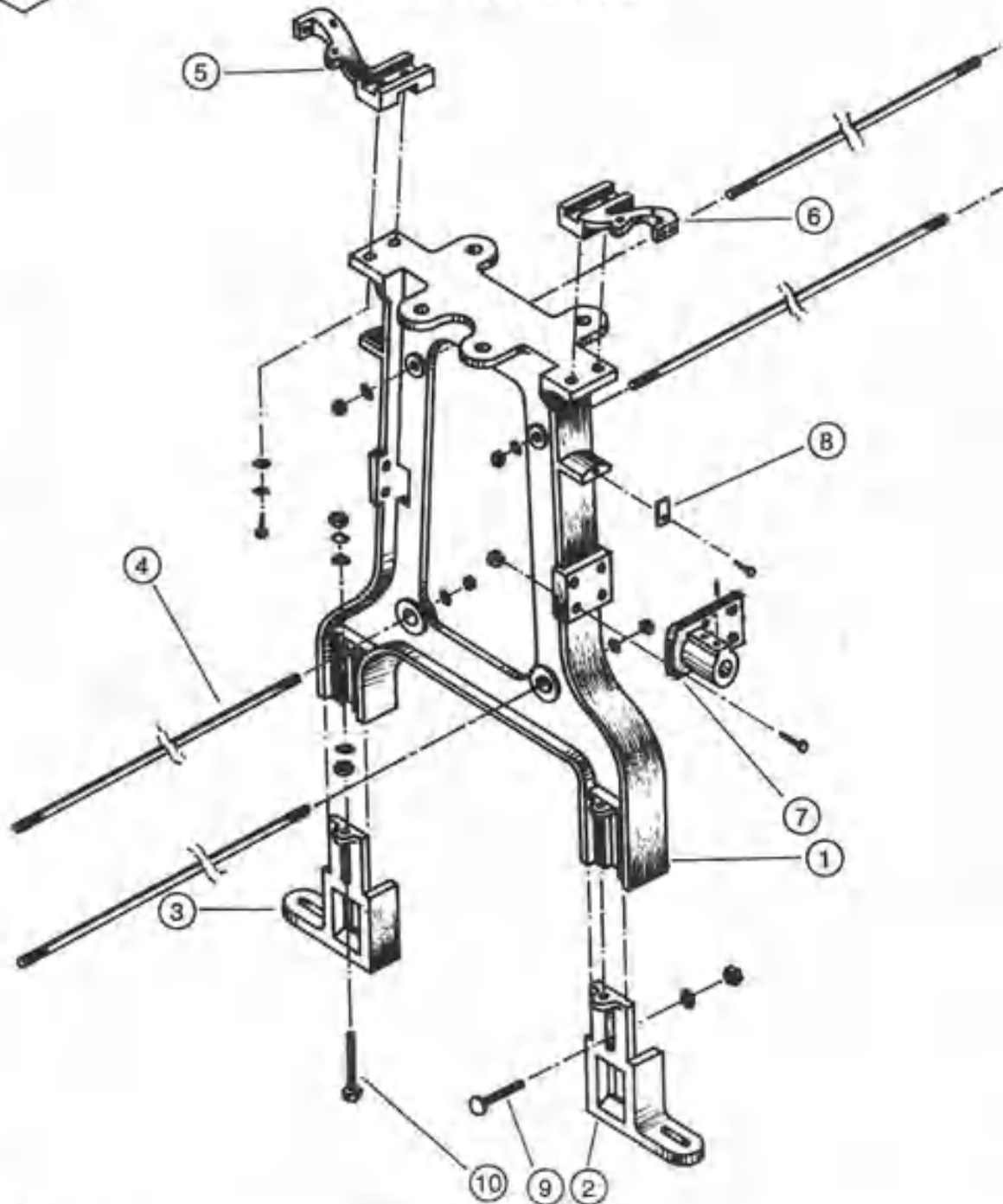

- (1) 71-38-2x Leg
- (2) 71-39-Leg Adjuster RH
- (3) 71-39-2Leg Adjuster LH
- (4) RD -2225 Tie Rod
- (5) 71-261 Bracket LH

- (6) 71-260 Bracket RH
- (7) MDP 115 Main Supply Support
- (8) Guard For Conveyor Belt
- (9) Carriage Bolt
- (10) Hex Pin

FRAME ASSEMBLY

RJK

- (1) 71-1-2 Frame
- (2) 71-6-2 Gasket
- (3) 71-2X Frame Cap
- (4) 71-17-15 Stud (Trip Lever Pin)
- (5) 71-652 Spring Pin
- (6) Press Button Oiler
- (7) 71-7-2X Yoke Assembly
- (8) 71-8-2 Yoke Shaft
- (9) 71-16 Oil Ring
- (10) 71-10-2 Yoke Shaft Lever
- (11) 71-12 Link (Taper)
- (12) 71-11 Stud
- (13) 71-26 Link Stud Block (Square)
- (14) 71-27-2X Plunger and Link Assembly
- (15) 71-26X Link Stud Block (Round)
- (16) 71-5-032 Gasket
- (17) PF 301 Plug
- (18) 71-22X Trip Lever
- (19) Pin 110 Trip Lever Clip
- (20) OL-6208 Oil Connection
- (21) Oil Pipe

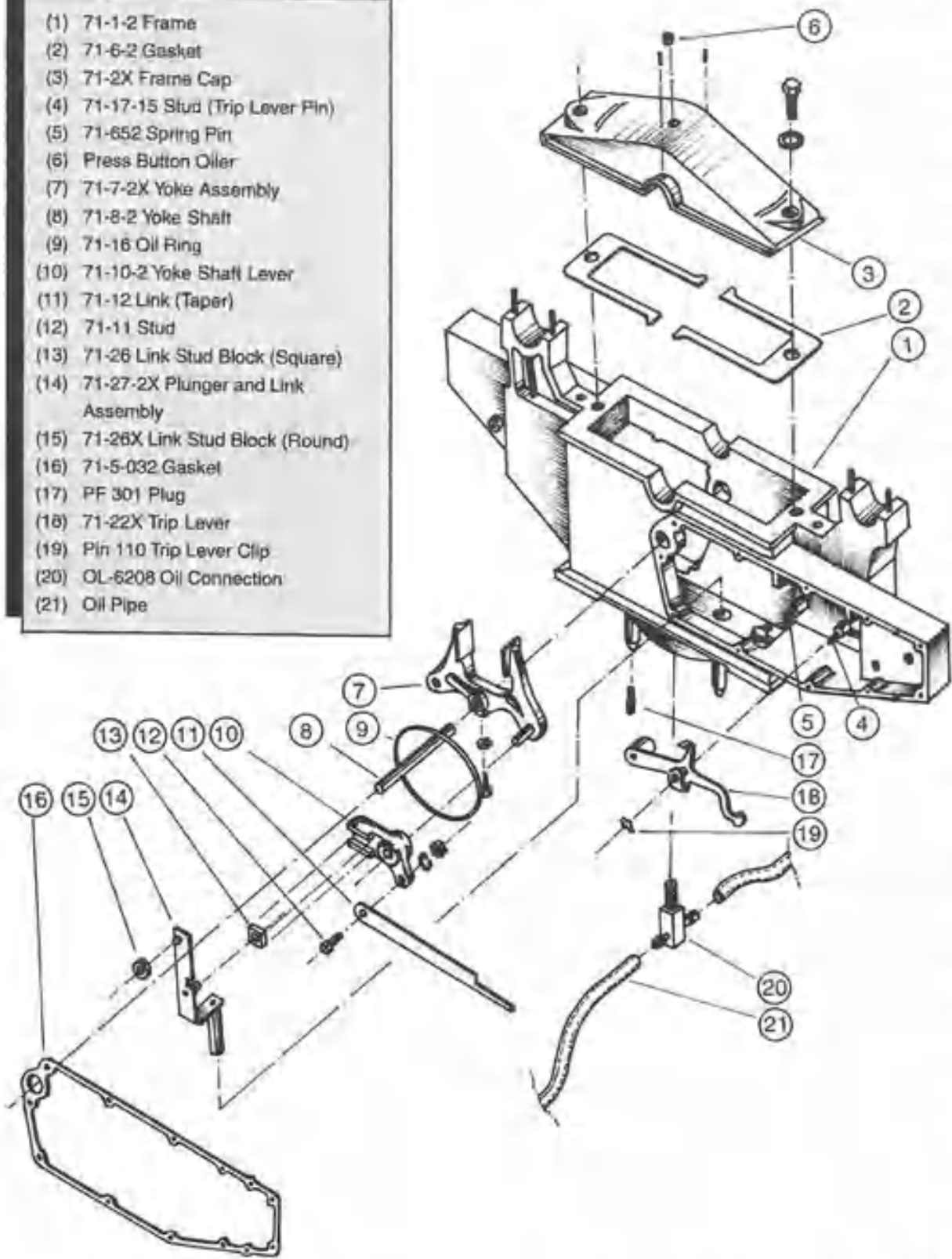

FRAME COVER ASSEMBLY

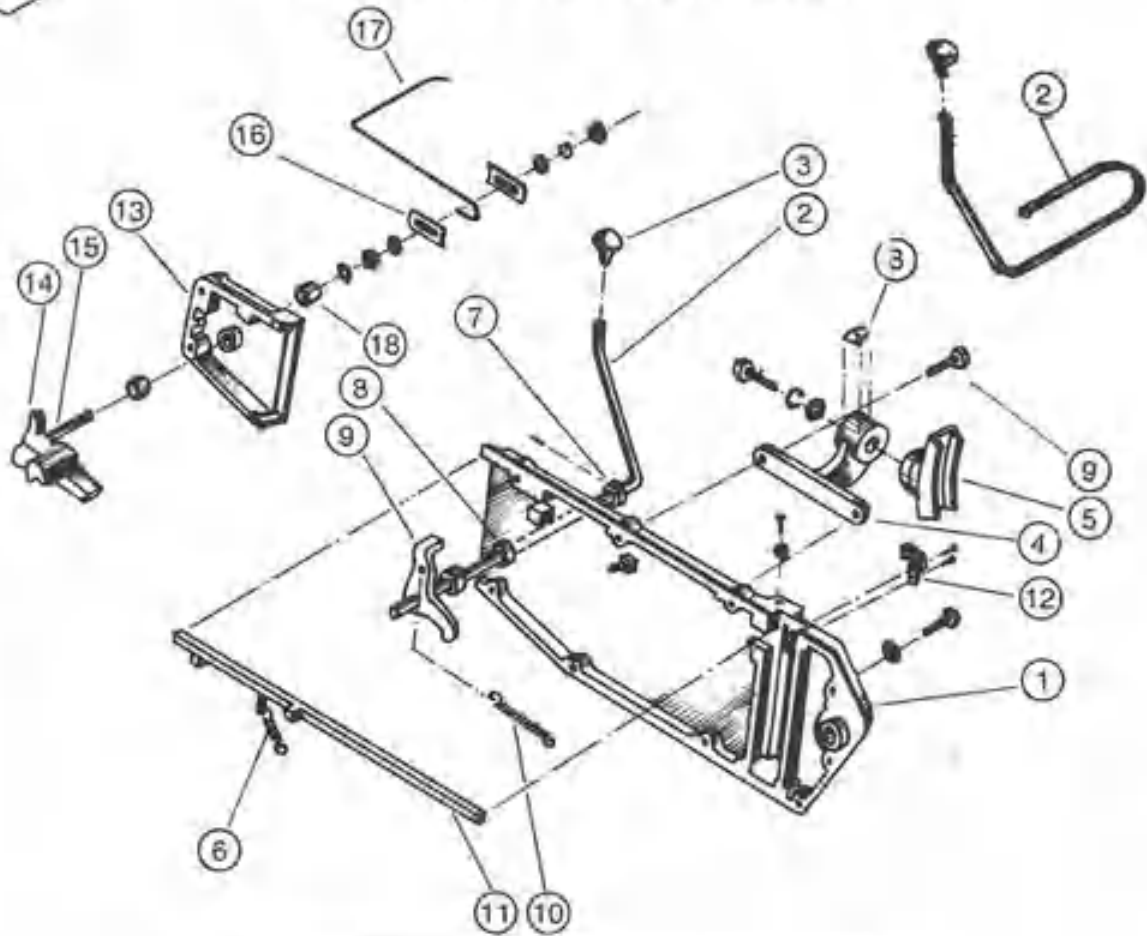

- (1) 71-3-4x Frame Cover
- (2) 71-28-24x Intermediate Starting Handle (LH RH)
- (3) 71-32-7 KNOB
- (4) 71-45-6xy Builder Cam Bracket on Side Cover
- (5) 71-45-6x Builder Cam Half Round Bracket
- (6) 71-221 Link Lock Spring
- (7) Co-136-Cax Collar
- (8) 71-13-3 Roll
- (9) Starting Handle Lever
- (10) 71-30 Spring
- (11) 71-14x Link Lock Assembly
- (12) Fluff Preventer
- (13) Frame Cover End Piece
- (14) 71-19-3x Pawl
- (15) 71-19-3xx Pawl Pin
- (16) 71-21-4CA Adjusting Clamp
- (17) 71-33-7C3 Breakage Lever
- (18) Knurled Bush
- (19) Builder Cam Label

CAM SHAFT ASSEMBLY

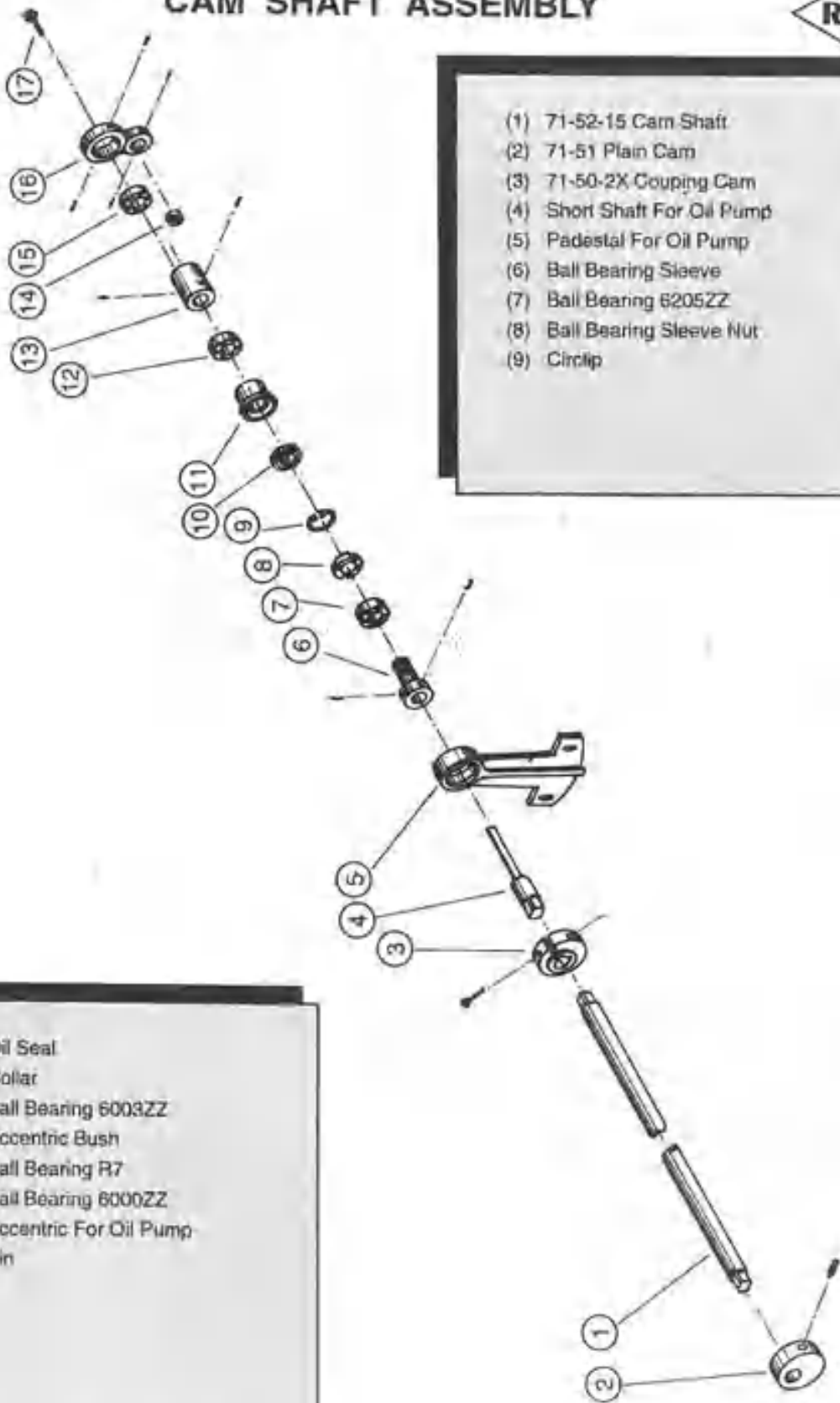

- (1) 71-52-15 Cam Shaft
- (2) 71-51 Plain Cam
- (3) 71-50-2X Couping Cam
- (4) Short Shaft For Oil Pump
- (5) Padestal For Oil Pump
- (6) Ball Bearing Sleeve
- (7) Ball Bearing 6205ZZ
- (8) Ball Bearing Sleeve Nut
- (9) Circlip

- (10) Oil Seal
- (11) Collar
- (12) Ball Bearing 6003ZZ
- (13) Eccentric Bush
- (14) Ball Bearing R7
- (15) Ball Bearing 6000ZZ
- (16) Eccentric For Oil Pump
- (17) Pin

BEARING ASSEMBLY

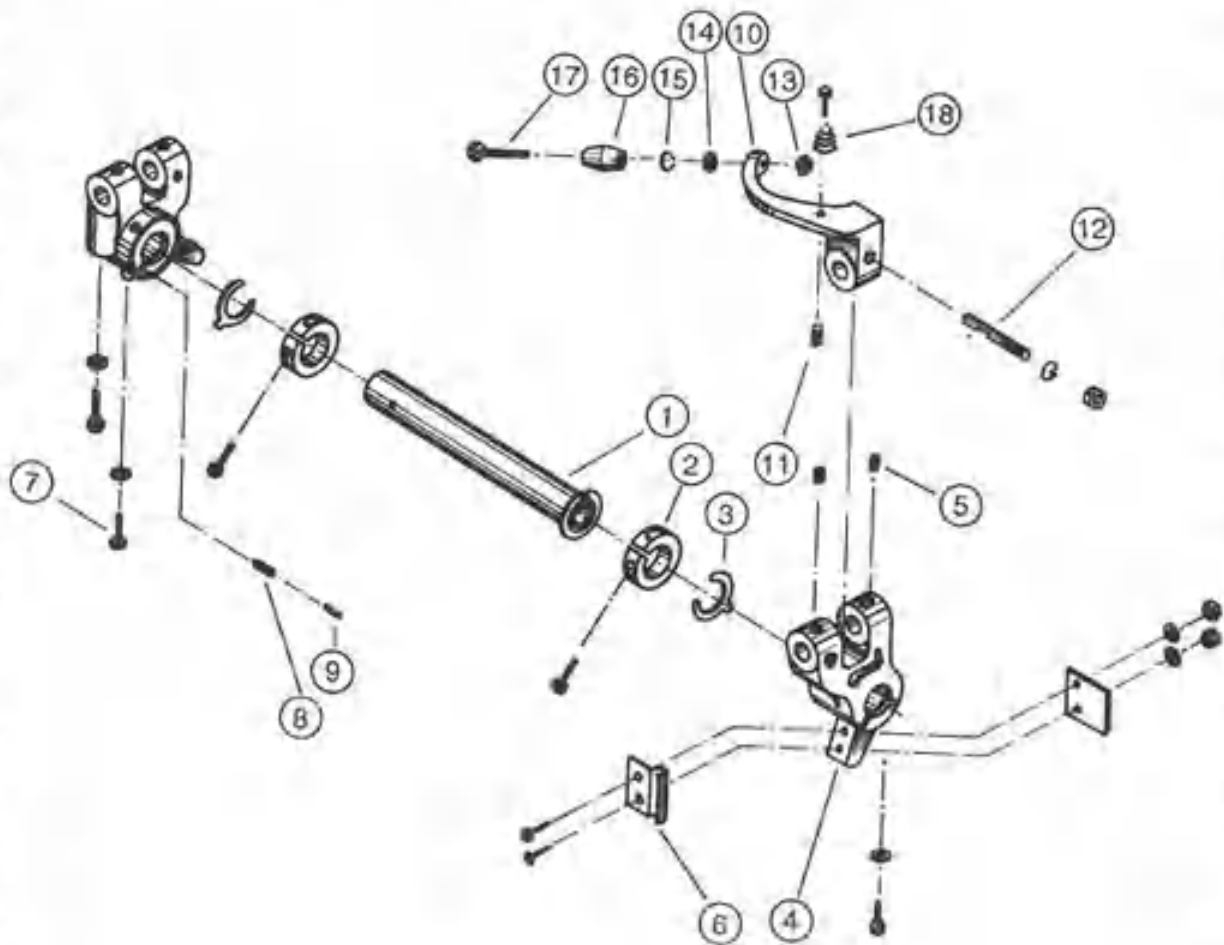

- (1) 71-53X Sleeve
- (2) 71-44-4X Stud Holder
- (3) 71-671 Friction Plate
- (4) 71-43-15X Bearing Assembly
- (5) Press Button Oiler
- (6) 71-278-2CA Upper Plate/Lower Plate
- (7) MDP 175 Slow Falling Pin With Nut
- (8) 71-667 Piston
- (9) CS-772 Spring
- (10) 71-45-6 Bulldozer Cam Lever

- (11) Dowel Pin
- (12) 71-49 Lock Pin (Half Round Pin)
- (13) Hax Nut
- (14) Washer
- (15) Spring Washer
- (16) Bulldozer Cam Lever Bowl
- (17) Bulldozer Cam Lever Pin
- (18) Bulldozer Cam Taper Spring

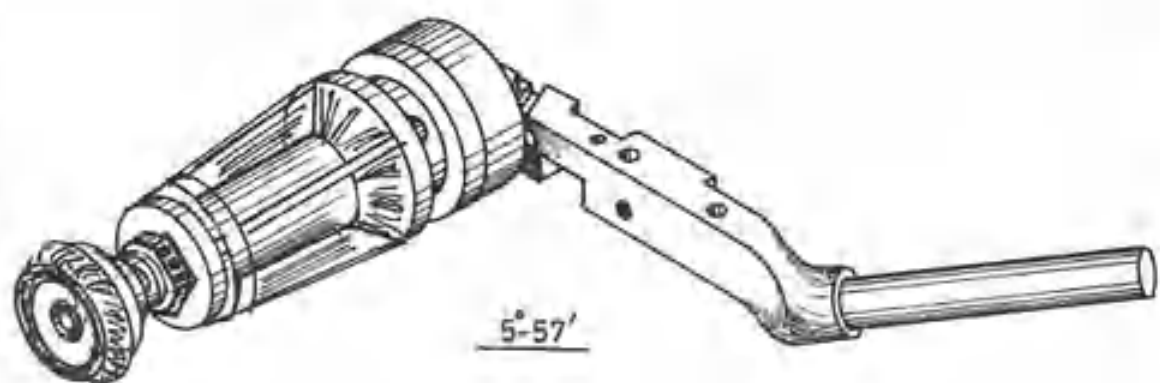
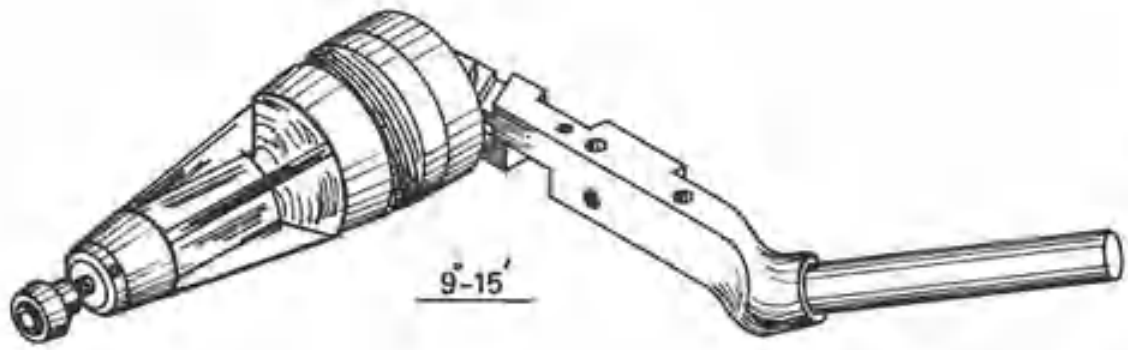

PAPER CONE HOLDER ASSEMBLY
(With Spindel Holder)



SPINDLE HOLDER ASSEMBLY

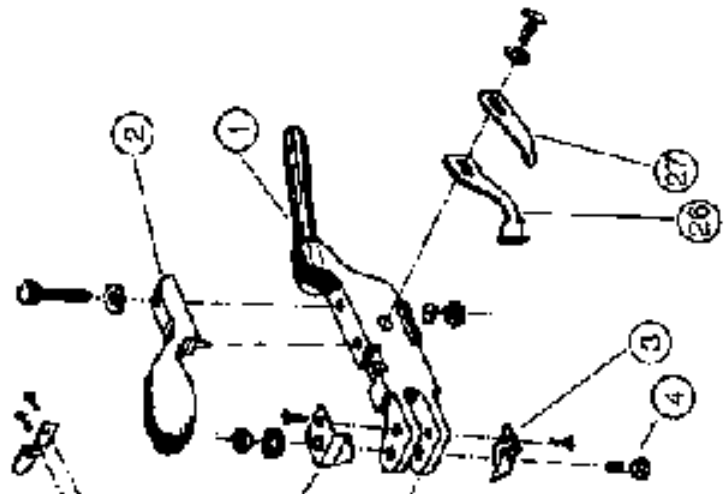

PAPER CONE HOLDER ASSEMBLY

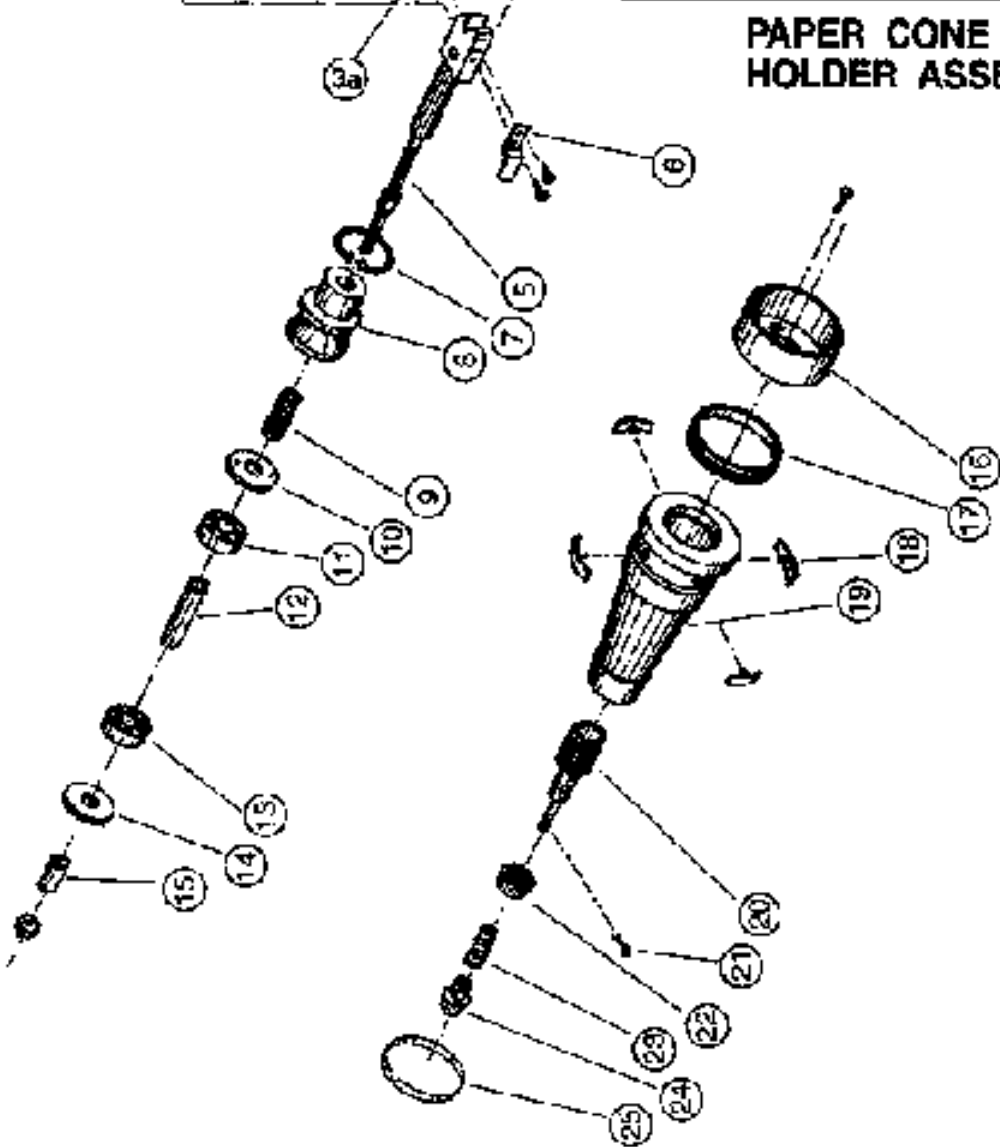

- (1) 71-41-18 Spindle Holder
- (2) 71-89-13X Weight
- (3) 71-398 Lower End
- (3a) 71-398 Upper End
- (4) 71-682 Stud (Spindle Holder Oil Pin)
- (5) Spindle For Paper Cone
- (6) M. S. Guard For Spindle
- (7) Circlip
- (8) Steel Collar (Specify Degree)
- (9) Spring
- (10) Check Nut Big
- (11) Ball Bearing 6000ZZ
- (12) Spacer Big
- (13) Ball Bearing 6000ZZ
- (14) Check Nut Small
- (15) Spacer Small
- (16) Plastic Guard
- (17) Rubber Band
- (18) Paper Cone Dog (Specify Degree)
- (19) Paper Cone Adaptor (Specify Degree)
- (20) Pin For Plastic Top
- (21) Cotter Pin
- (22) Check Nut Taper
- (23) Spring For Plastic Top
- (24) Plastic Top (Specify Degree)
- (25) Ball Band (Steel)
- (26) 71-42-2 Spindle Holder Spring Big
- (27) 71-42-2X Spindle Holder Spring Small

RJK

TRAVERSE SHAFT ASSEMBLY

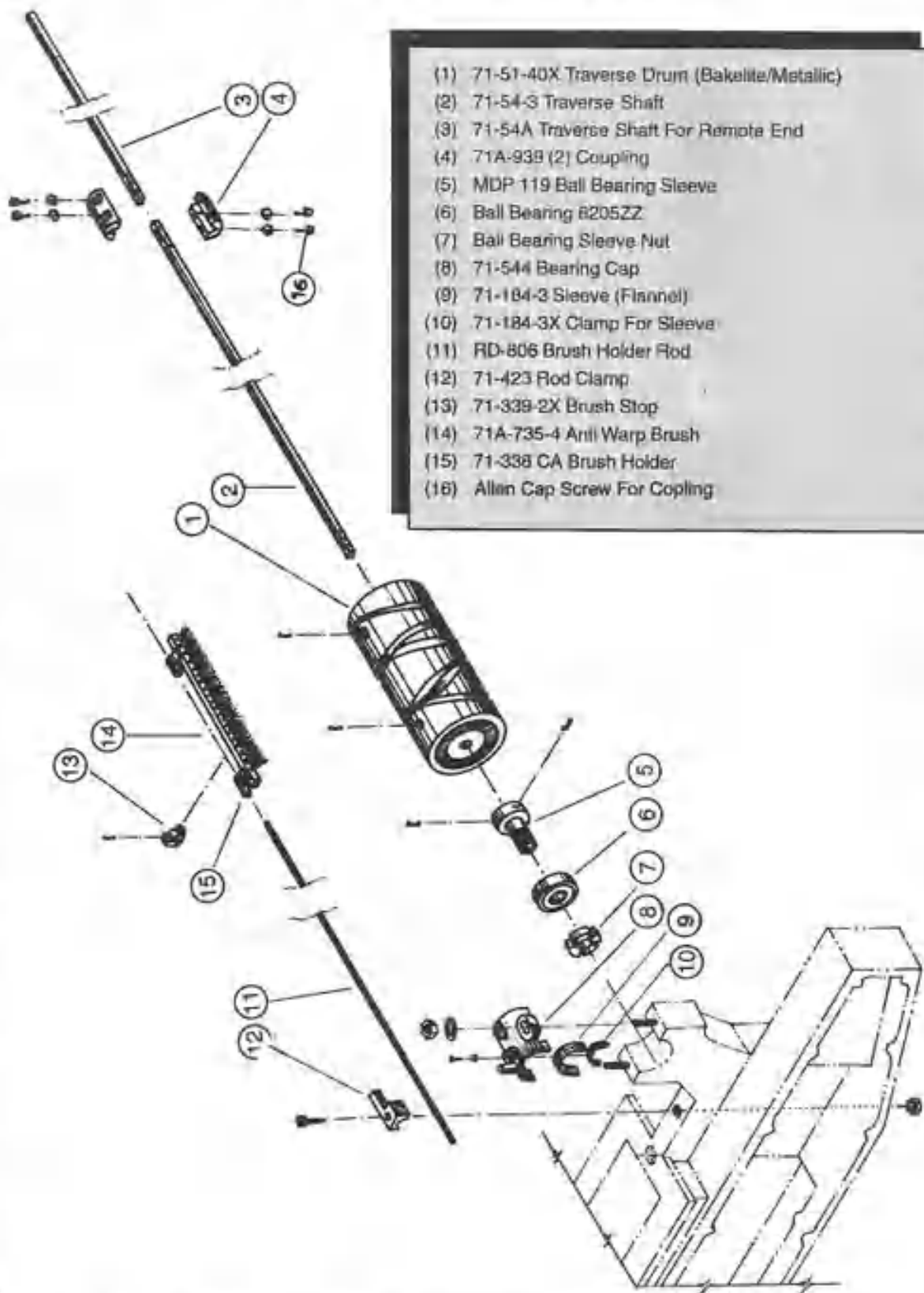

- (1) 71-51-40X Traverse Drum (Bakelite/Metallic)
- (2) 71-54-3 Traverse Shaft
- (3) 71-54A Traverse Shaft For Remote End
- (4) 71A-93B (2) Coupling
- (5) MDP 119 Ball Bearing Sleeve
- (6) Ball Bearing 8205ZZ
- (7) Ball Bearing Sleeve Nut
- (8) 71-544 Bearing Cap
- (9) 71-184-3 Sleeve (Flannel)
- (10) 71-184-3X Clamp For Sleeve
- (11) RD-806 Brush Holder Rod
- (12) 71-423 Rod Clamp
- (13) 71-339-2X Brush Stop
- (14) 71A-735-4 Anti Warp Brush
- (15) 71-338 CA Brush Holder
- (16) Allen Cap Screw For Coupling

REMOTE END ASSEMBLY

RJK

- (1) 71-257-6 Remote End Bracket
- (2) Angle For Oil Pump
- (3) 71-258-2 Stud
- (4) 71-256x Remote End Pulley
- (5) Ball Bearing 6205 ZZ
- (6) Cover For Remote End Pulley
- (7) Oil Pump Assembly
- (8) Hex Pin

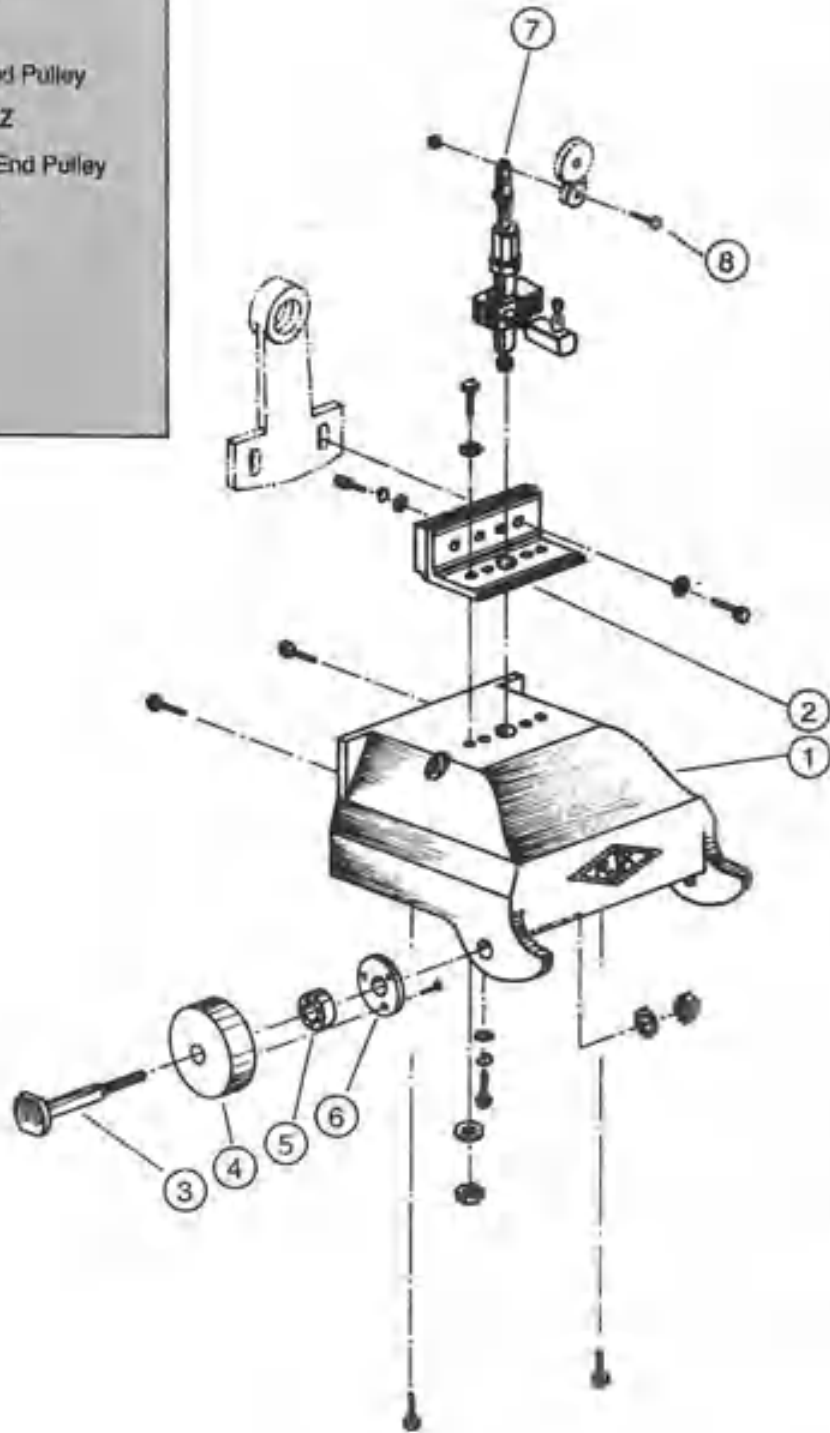

OIL PUMP ASSEMBLY

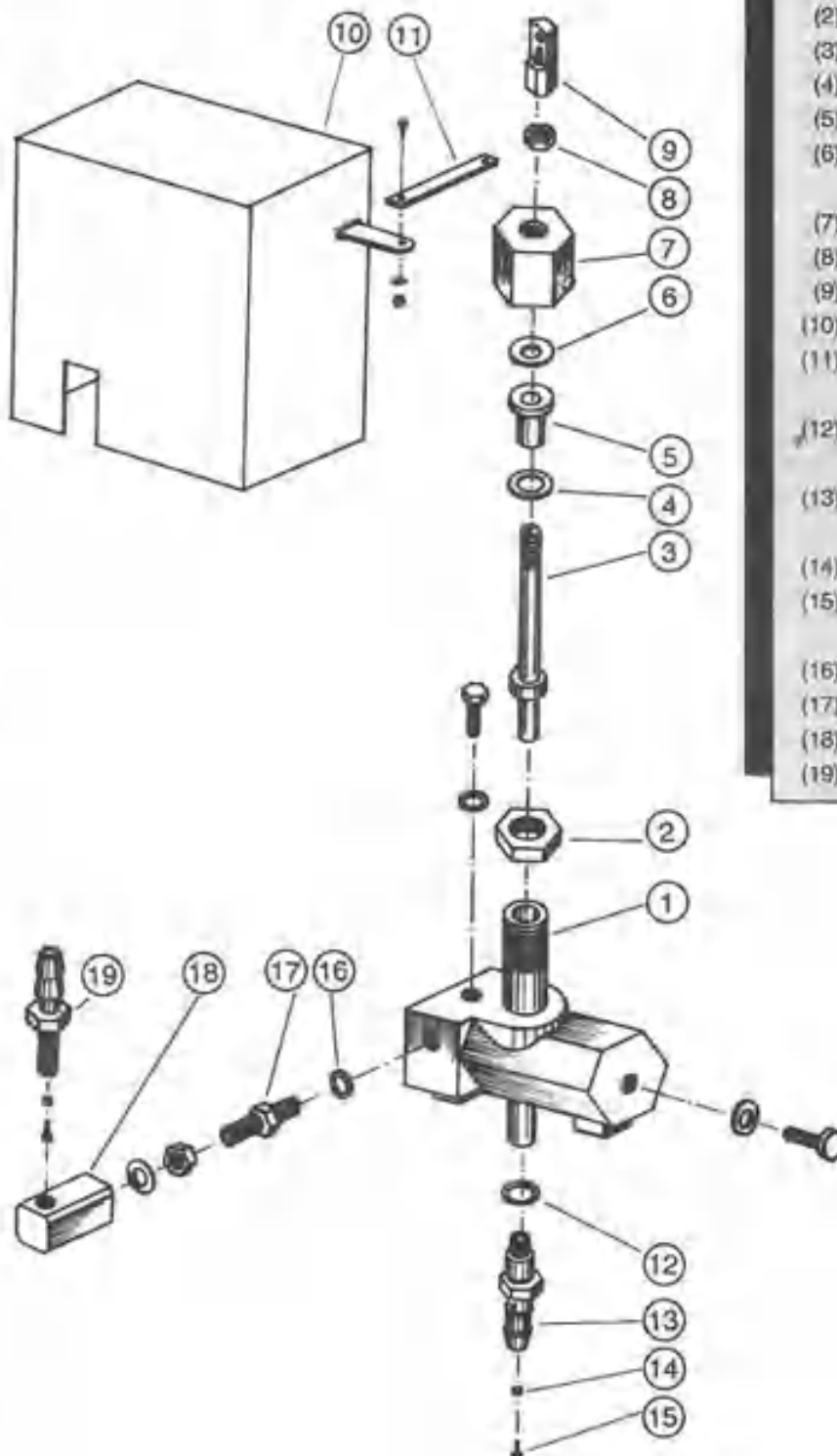

- (1) Oil Pump Body
- (2) Check Nut
- (3) Spindle For Oil Pump
- (4) Washer For Oil Pump
- (5) Collar For Oil Pump
- (6) Rubber Washer For Oil Pump
- (7) Gland Nut
- (8) Hex Nut
- (9) Bracket For Eccentric
- (10) Oil Pump Cover
- (11) Strip For Holding Oil Pump Cover
- (12) Washer For Bottom Nipple
- (13) Non Return Nipple For Bottom of Oil Valve
- (14) Steel Ball
- (15) Pin For Restriction of Steel Ball
- (16) Washer
- (17) Nipple For Valve
- (18) Bottom Band For Valve
- (19) Nipple

OIL TANK ASSEMBLY

RJK

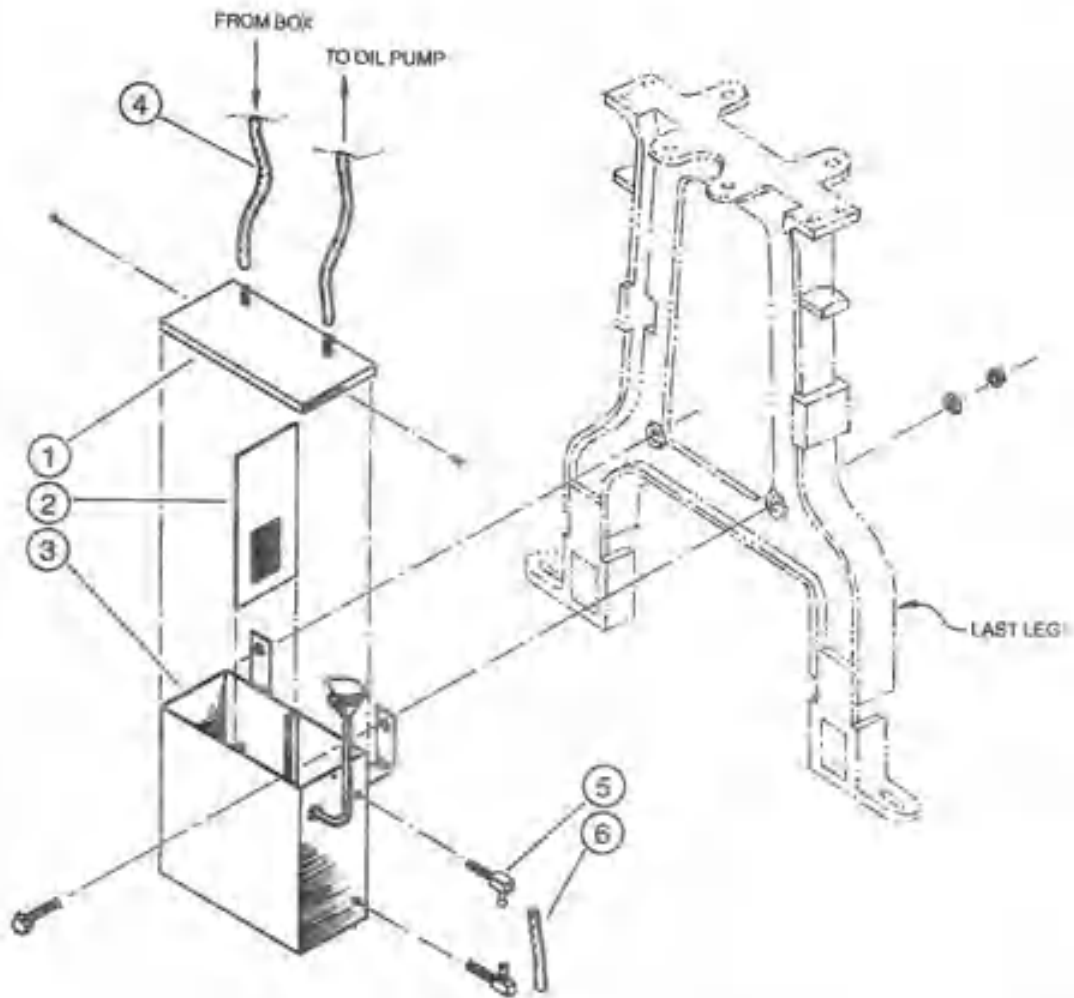

OIL TANK ASSEMBLY

- (1) Oil Tank
- (2) Oil Strainer
- (3) Oil Tank Cover
- (4) Plastic Pipe
- (5) Nipple
- (6) Plastic Pipe

CHAIN HOUSING ASSEMBLY

- (1) 71-104-3 Chain Housing Guard
- (2) MDP 123 Chain Housing Bracket Pin
- (3) 71-252-5 Stud
- (4) Circlip
- (5) Ball Bearing 6205 ZZ
- (6) BE 700 Conveyor Ball
- (7) 71-255-2 Conveyor Pulley
- (8) 71-251-3X Housing
- (9) 71-59-1B Sprocket Wheel
- (10) Key
- (11) 71-100-83 Chain
- (12) 71-259-3 Cover
- (13) Clamp For Conveyor Brush
- (14) Conveyor Brush

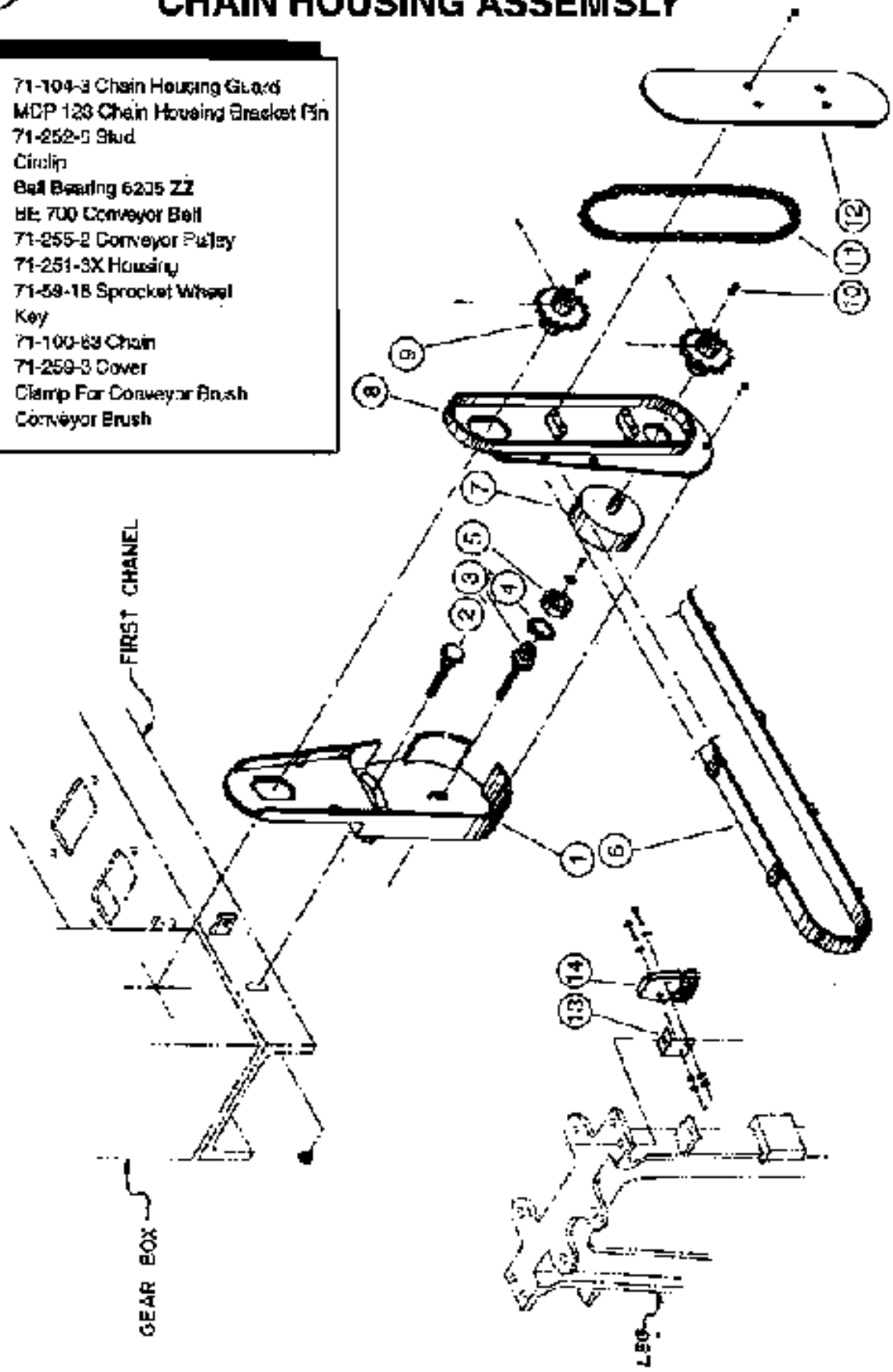

FIRST CHANEL

GEAR BOX

LEG

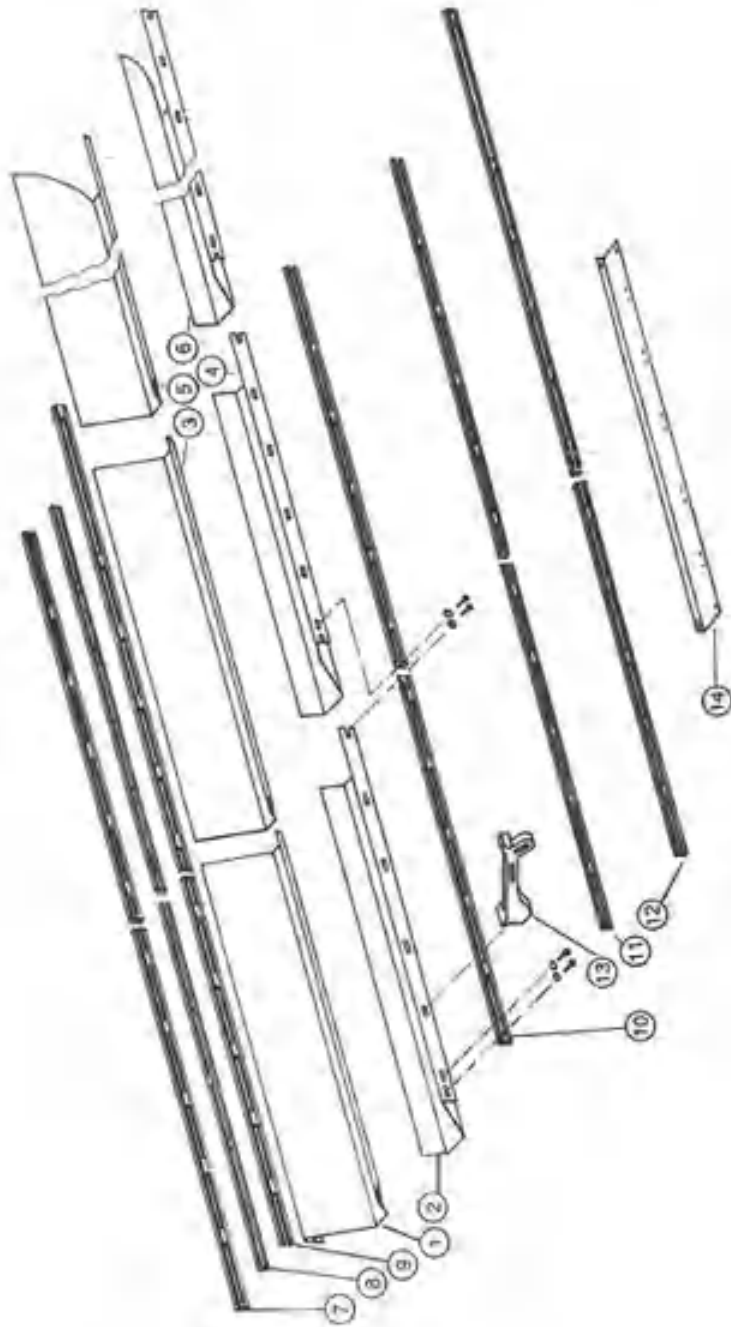

- (1) 71-267-2 Trough LH (No. 1.)
- (2) 71-267-2 Trough RH (No. 1.)
- (3) 71-267-2 Trough LH (Intermediate)
- (4) 71-267-2 Trough RH
- (5) 71-267-2 Trough LH (Rear End)
- (6) 71-267-2 Trough RH (Rear End)
- (7) 71-267-CA Tension Flat LH (No. 1.)

- (8,11) 71-267-CA Tension Flat RH (Intermediate)
- (9) 71-267-CA Tension Flat LH (Rear End)
- (10) 71-267-CA Tension Flat RH (No. 1.)
- (12) 71-267-CA Tension Flat RH (Rear End)
- (13) 71A-264-11 Bracket (Small)
- (14) 71-271-Bell Guard

RJK

SHELF

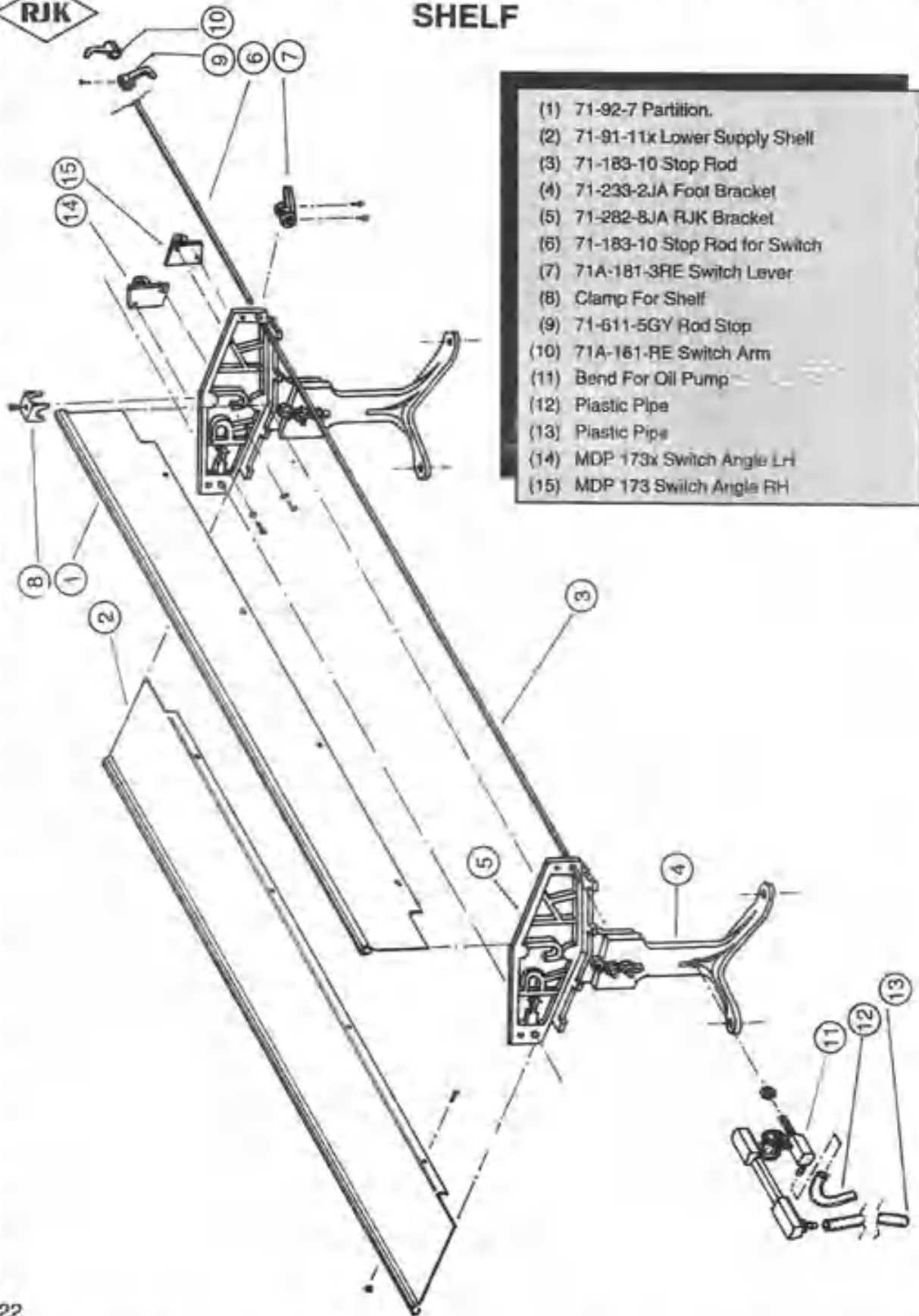



REWINDING SUPPLY

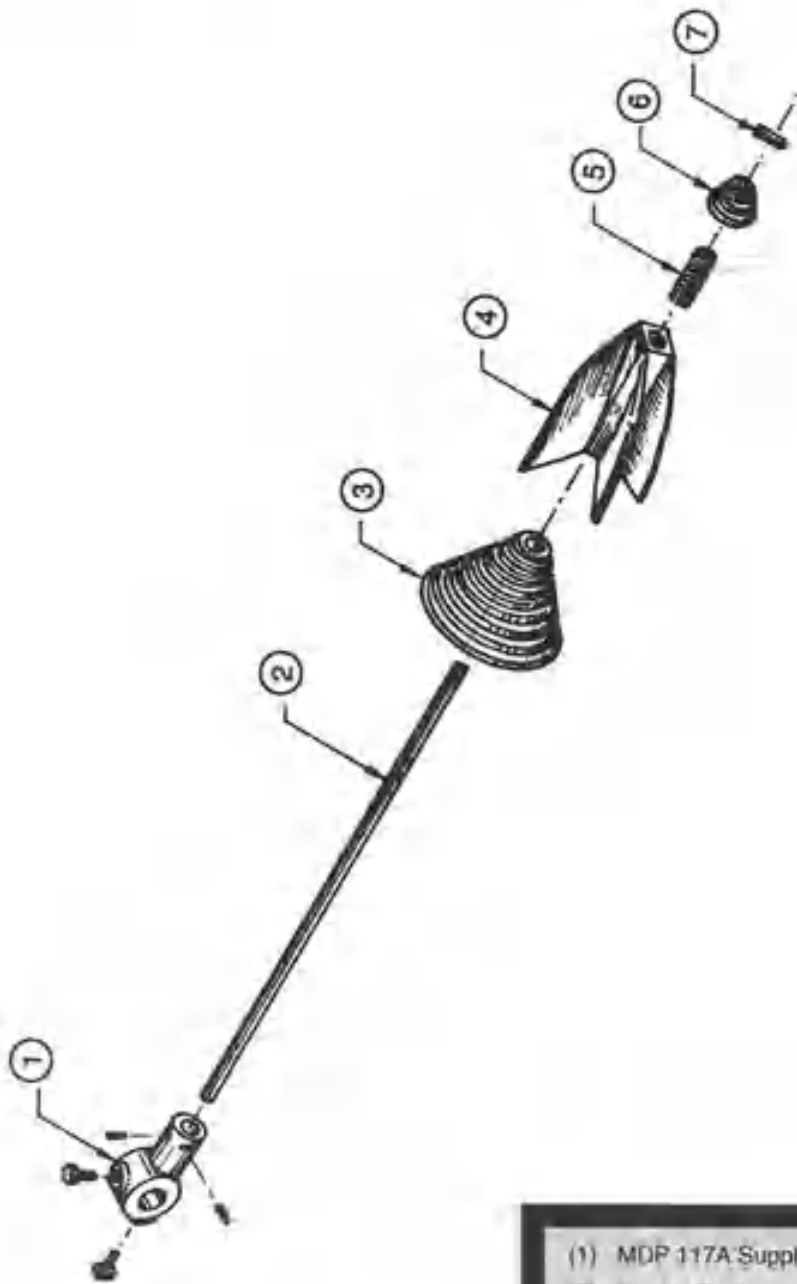

- (1) MDP 117A Supply Bracket
- (2) Supply Stud
- (3) PVC Cap Big
- (4) Rubber Holder
- (5) Spring
- (6) PVC Cap Small
- (7) Dowell Pin

TROLLEY

RJK

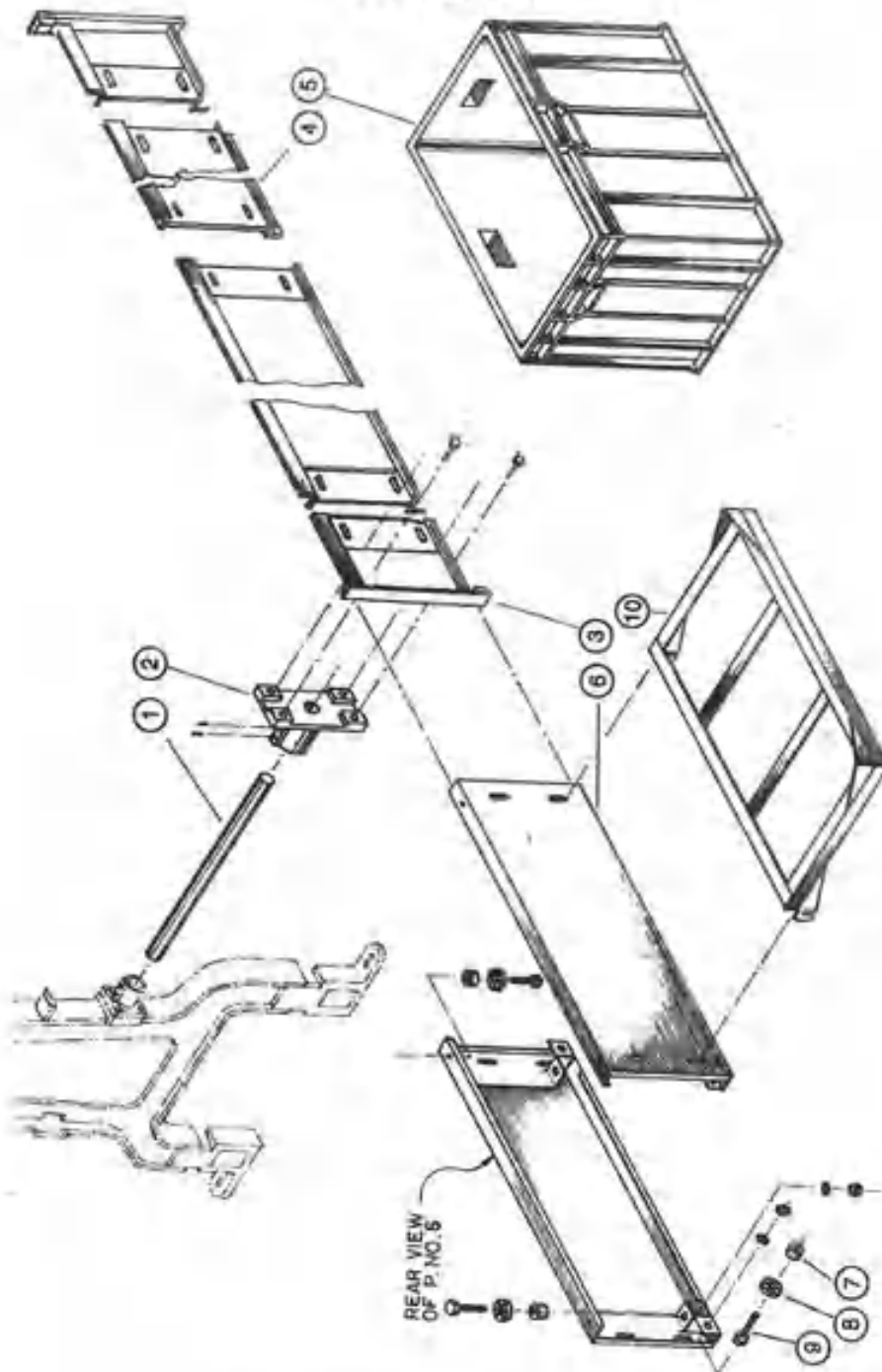

- (1) MDP 118 Bar For Trolley Bracket
- (2) MDP 114 Trolley Rail Bracket
- (3) MDP 122 Rail For Trolley
- (4) MDP 121 Rail For Trolley (Intermediate)
- (5) MDP 101 Bobin Container (Plastic Crate)

- (6) Trolley With Ball Bearings
- (7) Collar
- (8) MDP 109 Ball Bearing 6200 ZZ
- (9) MDP 104 Roller Pin
- (10) Bobbin Container Stand

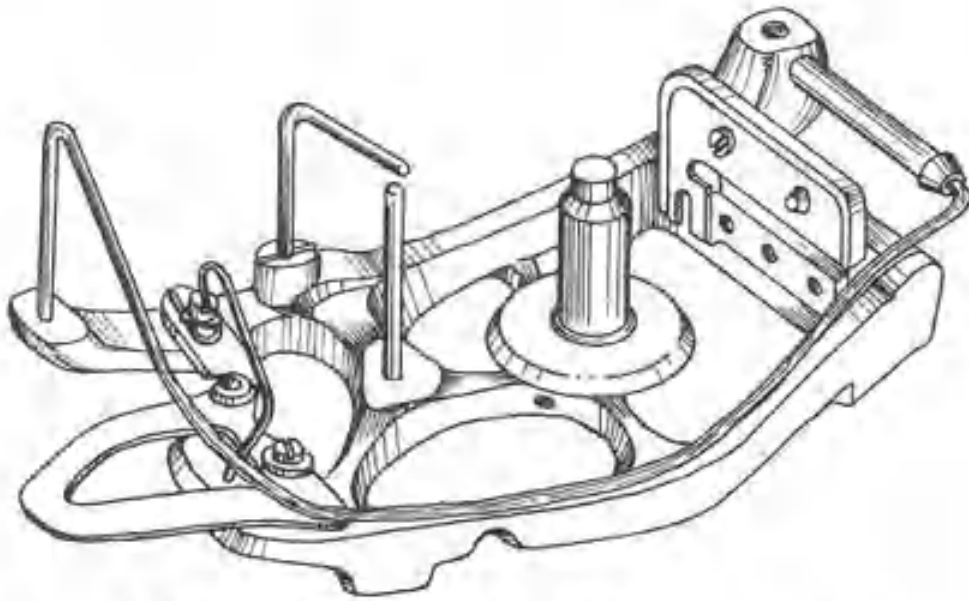

ORDINARY WAX TENSION DEVICE

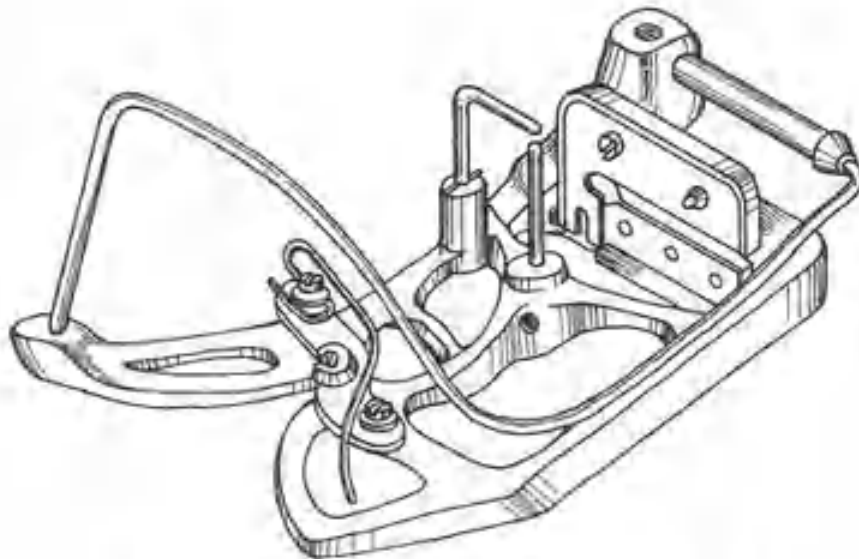

ORDINARY TENSION DEVICE

O. W. TENSION ASSEMBLY

RJK

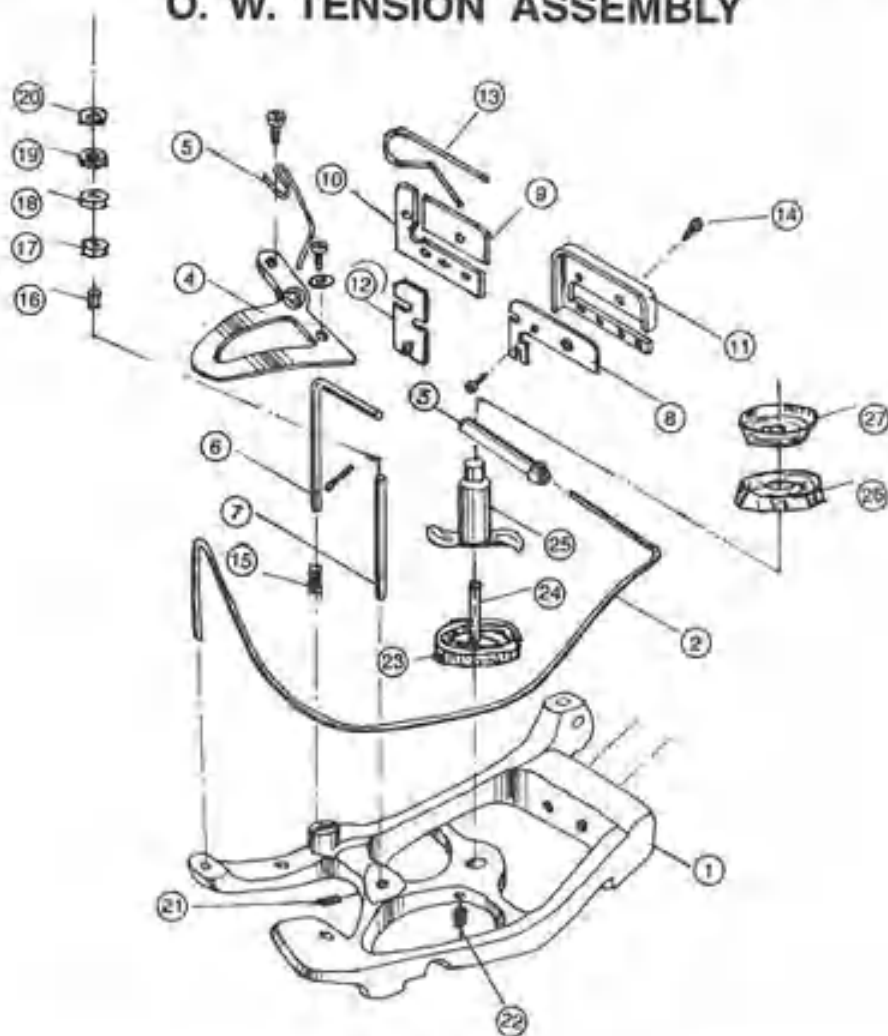

- (1) 71-420-50 X Ordinary Waxing Tension Device Only
- (2) 71-419 X Bail Wire
- (3) 71-426-4 CR X Bail Sleeve
- (4) Waxing Pan
- (5) 71-410 Guide Plate Wire
- (6) 71-R-1027-3 Weight Retainer
- (7) 71A-202-13 Tension Disc Pin
- (8) Shim For Slub Catcher
- (9) 71-1076-2X Blade
- (10) 71A-1076-2 Blade
- (11) 71A-1077-2 Cover
- (12) Shim
- (13) Spring For Slub Catcher

- (14) L. H. Threaded Slub Catcher Screw
- (15) Spring For Weight Retainer
- (16) Tension Collar
- (17) Tension Disc
- (18) Tension Disc
- (19) Flannel Washer
- (20) Tension Weight (5, 7, 12, 24 Gms.)
- (21) Screw For Tension Disc Pin
- (22) Screw For Knurling Pin
- (23) Knotch Type Disc
- (24) Knurling Pin
- (25) Waxing Dog
- (26) Waxing Disc
- (27) Waxing Disc

ORDINARY TENSION ASSEMBLY

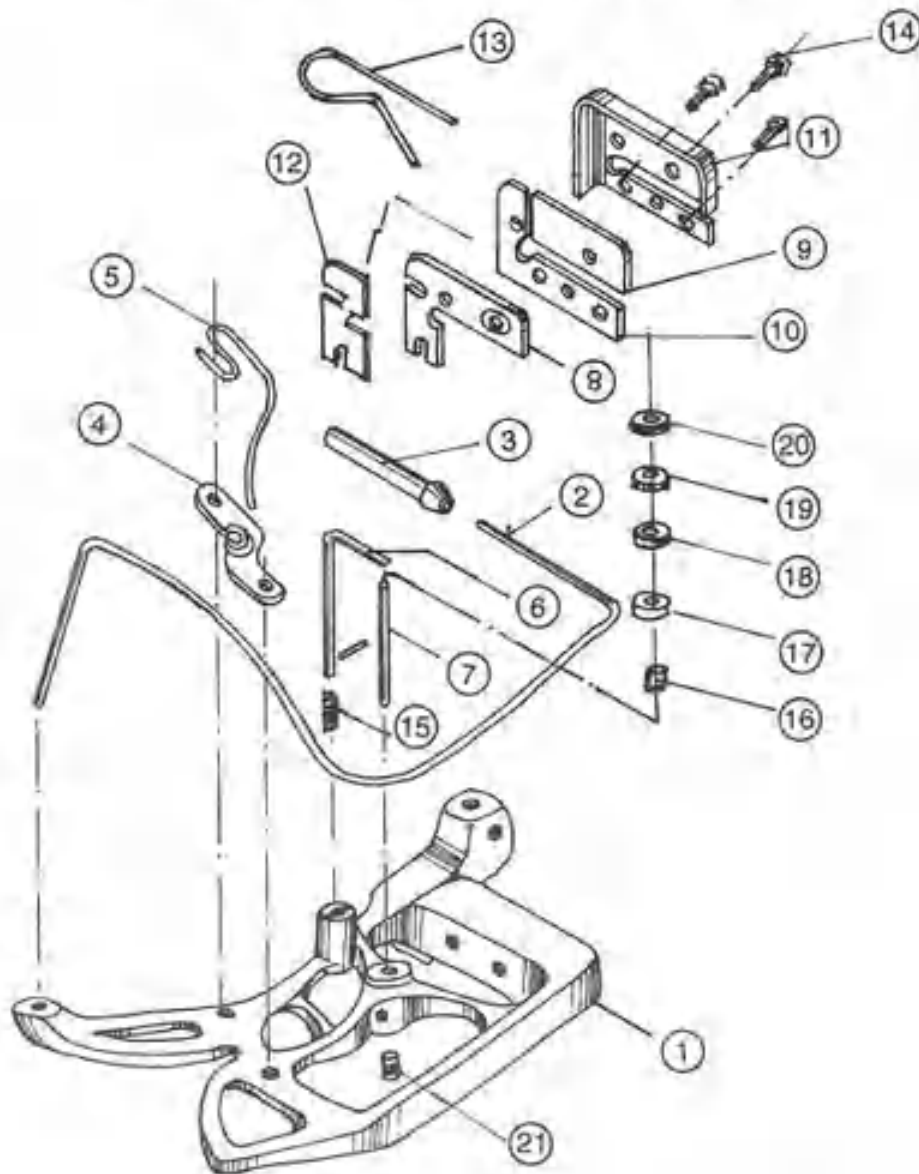

- (1) 71-420-50 Ordinary Tension Device Only
- (2) 71-419 Ball Wire
- (3) 71-426-4 CR X Bail Sleeve
- (4) 71-409 Guide Plate
- (5) 71-410 Guide Plate Wire
- (6) 71-R-1027-3 Weight Retainer
- (7) 71A-202-13 Tension Disc Pin
- (8) Shim For Slub Catcher
- (9) 71-1076-2X Blade
- (10) 71A-1076-2 Blade
- (11) 71A-1077-2 Cover

- (12) Shim
- (13) Spring For Slub Catcher
- (14) L. H. Threaded Slub Catcher Screw With Nut
- (15) Spring For Weight Retainer
- (16) Tension Collar
- (17) Tension Disc
- (18) Tension Disc
- (19) Flannel Washer
- (20) Tension Weight 4 Type (5, 7, 12: 24 Gms.)
- (21) Screw For Tension Disc Pin

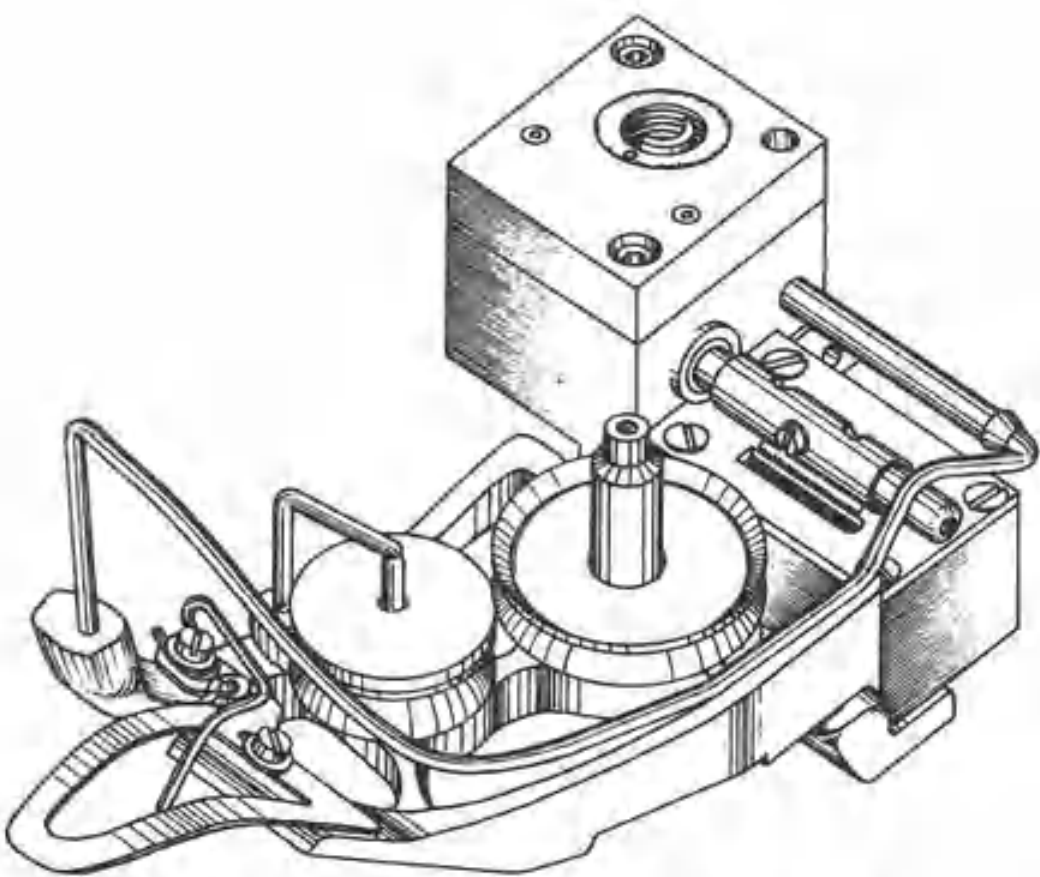

ATIRA WAXING TENSION DEVICE



ATIRA WAX TENSION ASSEMBLY

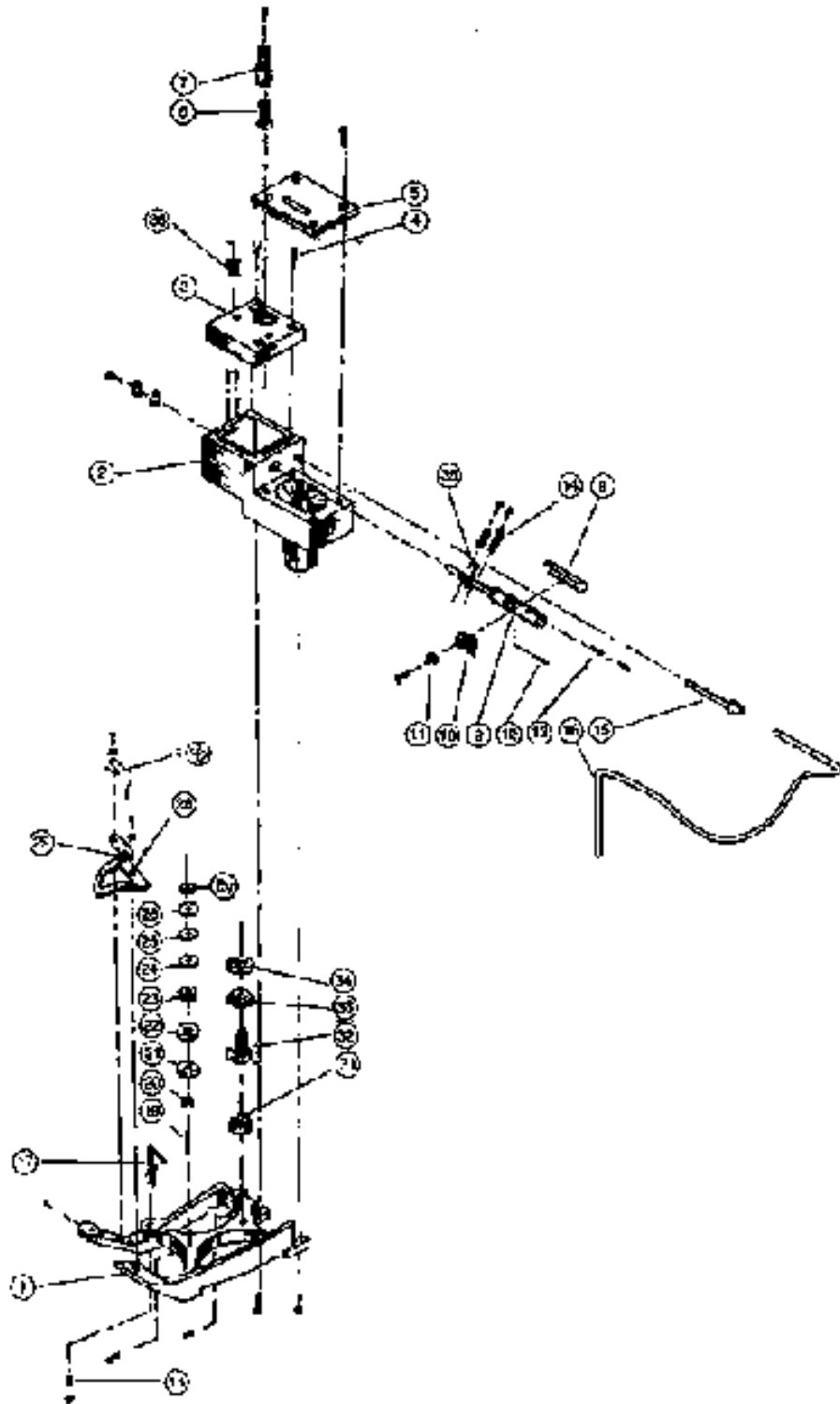

- (1) ATIRA Wax Tension (Only)
- (2) ATIRA Slub Catcher Body
- (3) Square Cover With Nut
- (4) Allen for Bail Wire
- (5) Platform
- (6) Setting Allen With Slot
- (7) Worm
- (8) Spindle for ATIRA Slub Catcher
- (9) Serrated Blade Cover
- (10) Serrated Blade
- (11) Serrated Blade Spring
- (12) Pivot Small
- (13) Pivot Lock Screw
- (14) Tension Spring For Spindle
- (15) 71/426-4CHX Bail Sleeve
- (16) 71-419 Bail Wire
- (17) 71-R-1027-3 Weight Retainer
- (18) Spring For Weight Retainer
- (19) 71A-202-13 Tension Disc Pin
- (20) 71A-175-2 Collar
- (21) 71A-153-17 Tension Disc
- (22) 71A-153-17 Tension Disc
- (23) Flannel Washer
- (24) WA-801 CA Tension Weight Red (5 gm)
- (25) WA-801 CA Tension Weight White (7 gm)
- (26) WA-801 CA Tension Weight Green (12 gm)
- (27) WA-801 CA Tension Weight Yellow (24 gm)
- (28) Waxing Pan
- (29) Yarn Guide
- (30) 71-409 Guide Plate Wire
- (31) Wax Knurling Pin (Counter Sunk)
- (32) Waxing Dog
- (33) Waxing Tension Disc
- (34) Waxing Tension Disc
- (35) 5/32" Setting Pin
- (36) Tension Spring for Spindle



ATIRA ORDINARY TENSION DEVICE

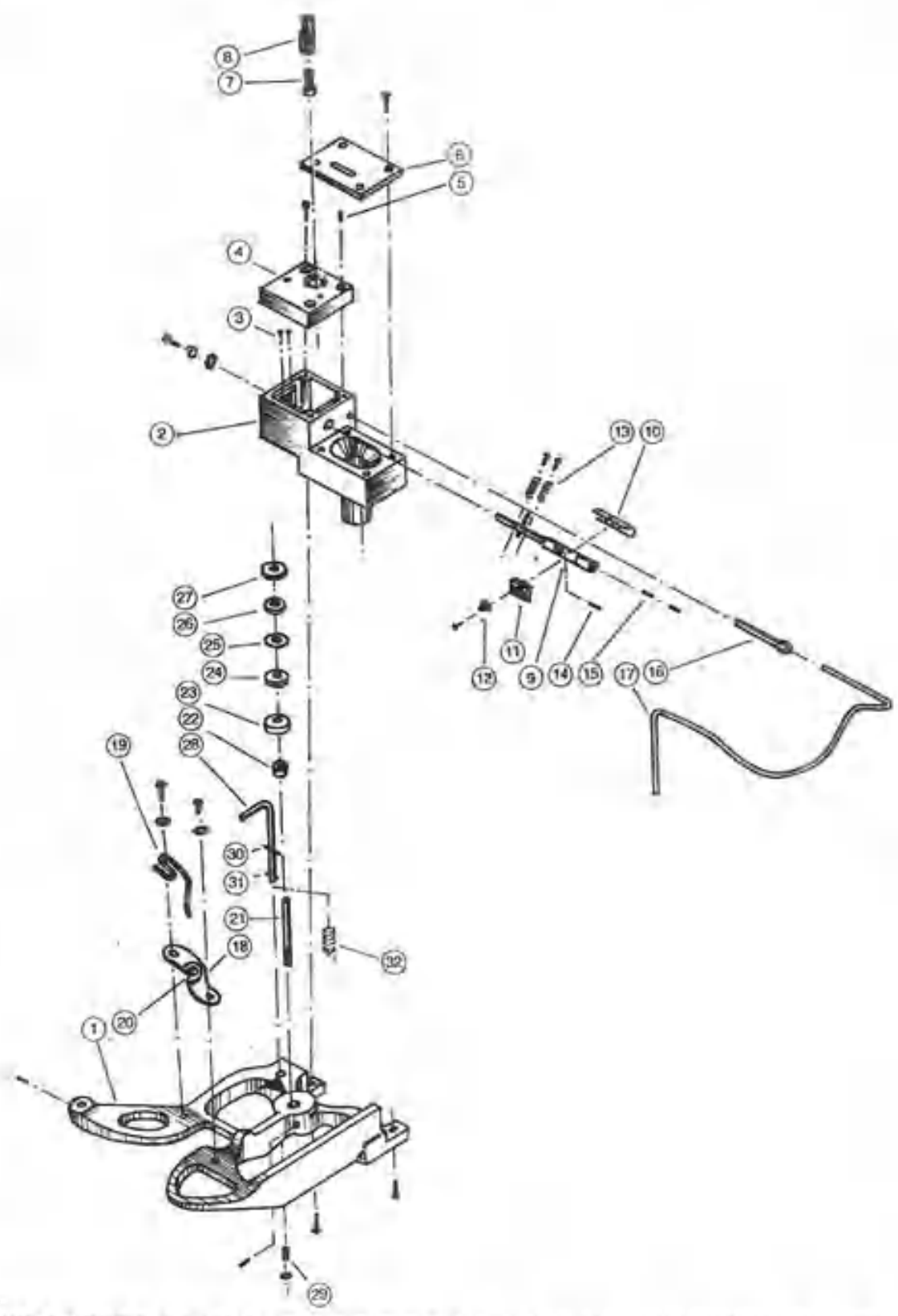

- (1) ATIRA Ordinary Tension
- (2) ATIRA Slub Catcher Body
- (3) Screw for Tension Spring
- (4) Square Cover with Nut
- (5) Allen For Bail Wire
- (6) Platform
- (7) Setting Allen With Slot
- (8) Worm
- (9) Spindle For ATIRA Slub Catcher
- (10) Serrated Blade Cover
- (11) Serrated Blade
- (12) Serrated Blade Spring
- (13) Tension Spring For Spindle
- (14) Pivot Small
- (15) Pivot Lock Screw
- (16) 71/426-4CRX Bail Sleeve
- (17) 71-419 Bail Wire For (Atira Ordinary)
- (18) Waxing Pan
- (19) 71-409 Guide Plate Wire
- (20) Yarn Guide
- (21) 171A-202-13 Tension Disc Pin
- (22) 71-475-2 Collar
- (23) 71A-153-17 Tension Disc
- (24) 71A-153-17 Tension Disc
- (25) Flannel Washer (Banat)
- (26) WA-801 CA Tension Weight Red (5 gm)
- (27) WA-801 CA Tension Weight Whight (7 gm)
- (28) 71-R-1027-3 Weight Retainer
- (29) Spring For Weight Retainer
- (30) Locking Pin
- (31) Lock Screw For Wax Knurling Pin
- (32) Spring For L Wire

SUGGESTED TENSION WEIGHTS AT HIGH SPEED WINDING
(WINDING SPEED UPTO 650 M³/M)

Count (Ne)	Tension Weight (including disc and flanne.) Grams
9-14	32.5-35.5
18-22	19.5-22.5
24-28	16.0-18.0
30-32	15.0-16.0
34-36	14.0-15.5
40-44	13.0-15.0
50-60	10.0-12.0
70-80	8.0-10.0
100-120	6.0-6.5

SLUB CATCHER SETTING (THOU)

Yarn Count (Ne)	Yarn Die (Thou)	Fixed Blade		Serrated Oscillating Blade		
		Carded	Combed	Combed	Carded	Light Combed
10	11.38	26-30	21-25	40-48	36-44	57-65
12	10.39	24-28	19-23	36-44	32-40	52-60
14	9.62	22-26	17-21	34-42	30-38	48-56
16	9.00	20-24	16-20	32-40	28-36	45-53
18	8.48	19-23	15-19	30-38	26-34	42-50
20	8.05	18-22	14-18	28-36	24-32	40-48
24	7.35	17-20	13-16	26-32	23-29	35-44
28	6.80	16-19	12-15	24-30	21-27	33-41
30	6.57	15-18	12-14	23-29	20-26	32-40
32	6.36	15-17	11-14	22-28	19-26	32-38
34	6.17	14-17	11-13	22-28	19-25	31-37
36	6.00	14-16	10-13	21-27	18-24	30-36
38	5.84	13-16	10-13	21-26	18-23	29-35
40	5.69	13-15	10-12	20-25	17-22	28-34
44	5.43	12-15	10-12	19-24	16-21	27-33
50	5.09	11-14	9-11	18-23	15-20	25-31
60	4.85	10-13	8-11	16-21	14-19	23-29
70	4.30	10-12	8-10	15-19	13-17	22-26
80	4.02	9-11	7-9	14-18	12-16	20-24
90	3.79	8-11	7-9	13-17	12-15	19-23
100	3.66	8-10	6-8	13-15	11-15	18-22
110	3.43	-	6-8	-	11-14	-
120	3.29	-	6-7	-	10-13	-

STEEL JAWS GAP SETTING

YARN COUNT		JAWS GAP SETTING IN 1/100 mm.		
No.	Carded Cotton Yarn	Combed Cotton, Rayon, Synthetic Staple	Artificial Silk	Wool & Wool Blended Yarns
4s	81	70	58	81
6s	66	57	47	66
8s	57	49	41	57
10s	51	44	36	51
12s	47	40	33	47
14s	43	37	31	43
16s	41	35	29	41
18s	38	33	27	38
20s	36	31	26	36
24s	33	28	24	33
26s	32	27	23	32
28s	31	26	22	31
30s	30	25	21	30
32s	29	24	20	29
34s	28	24	20	28
36s	27	23	19	27
40s	26	22	18	26
44s	24	21	17	24
48s	23	20	17	23
50s	23	20	16	23
60s	21	18	15	21
70s	19	17	14	19
80s	-	15	13	18
90s	-	15	12	17
100s	-	14	12	-
120s	-	13	11	-
150s	-	11	9	-

HOW TO OPERATE

1. Open the knob cover, unlock the locknut by special key only half round
2. Adjust jaws gap by rotating the counter knob as per yarn count requirement. See chart for count setting.
3. Lock the nut by special key and fix the knob cover. Now you are ready to use yarn clearing device.

HAMMER TYPE SUPPLY

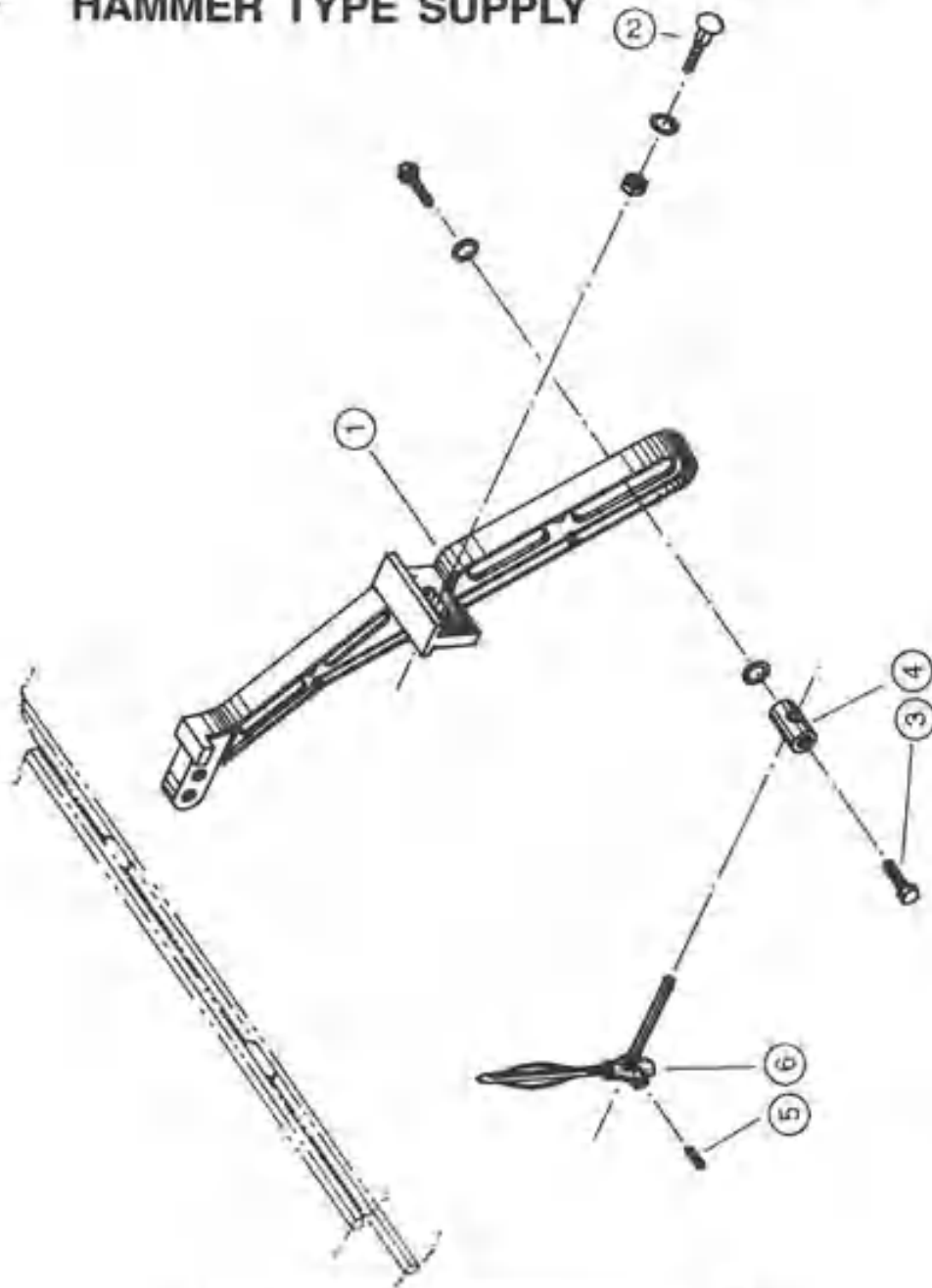

- (1) 71-264-11 Bracket (Long)
- (2) Machine Bolt
- (3) Hex Pin
- (4) Holder Datta
- (5) Allen Set Screw
- (6) 71-265-8 Holder

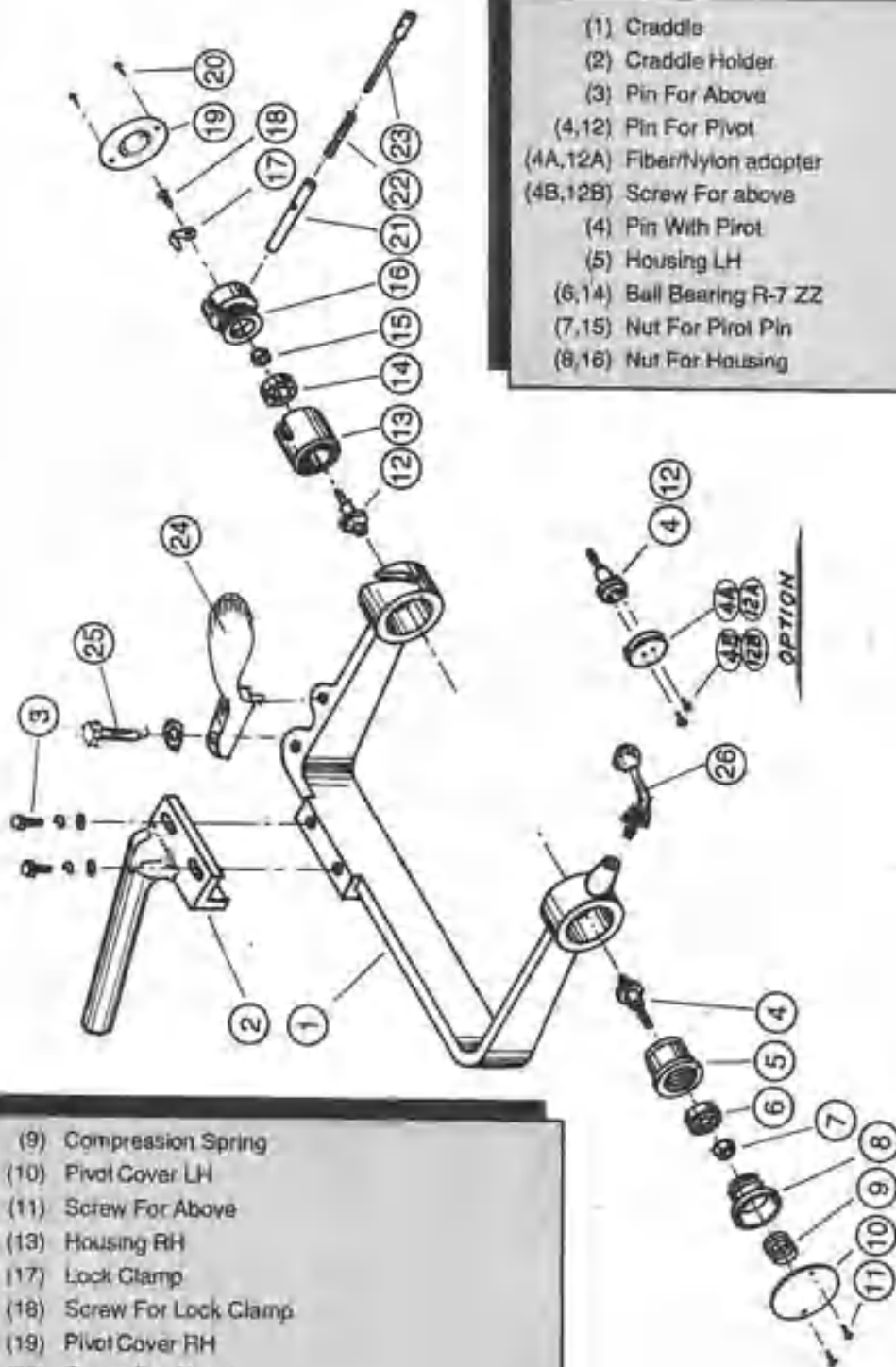

- (1) Cradle
- (2) Cradle Holder
- (3) Pin For Above
- (4,12) Pin For Pivot
- (4A,12A) Fiber/Nylon adapter
- (4B,12B) Screw For above
- (4) Pin With Pivot
- (5) Housing LH
- (6,14) Ball Bearing R-7 ZZ
- (7,15) Nut For Pivot Pin
- (8,16) Nut For Housing

- (9) Compression Spring
- (10) Pivot Cover LH
- (11) Screw For Above
- (13) Housing RH
- (17) Lock Clamp
- (18) Screw For Lock Clamp
- (19) Pivot Cover RH
- (20) Screw For Above
- (21) Pivot Handle
- (22) Spring For Pivot Handle
- (23) Pin For Pivot Handle

OPTION

CRADLE ASSEMBLY

RJK

CRADLE ASSEMBLY WITH COUNTER WEIGHT

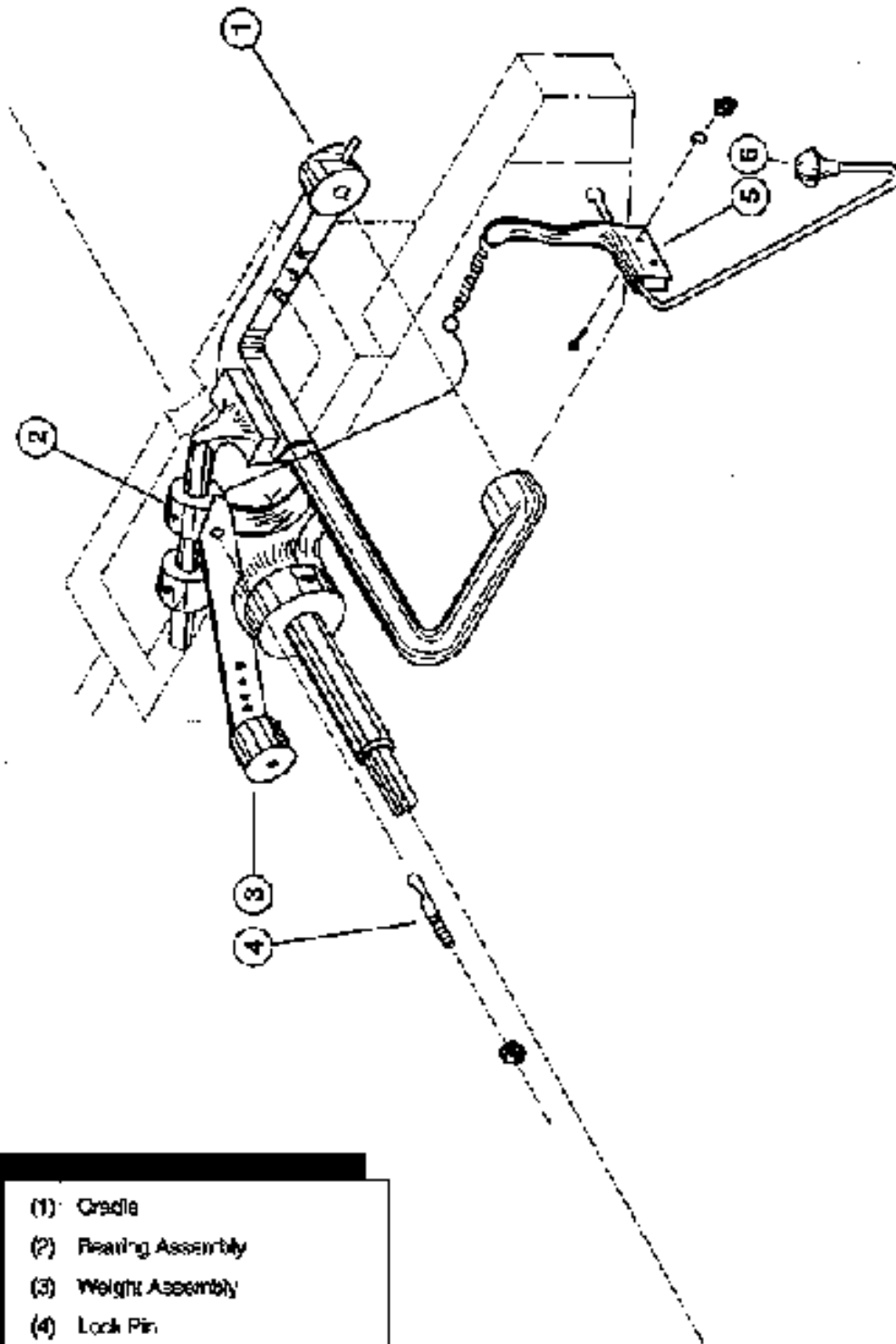

- (1) Cradle
- (2) Bearing Assembly
- (3) Weight Assembly
- (4) Lock Pin
- (5) Bracket With Spring And Wire
- (6) Starting Handle

BLOWER BODY

RJK

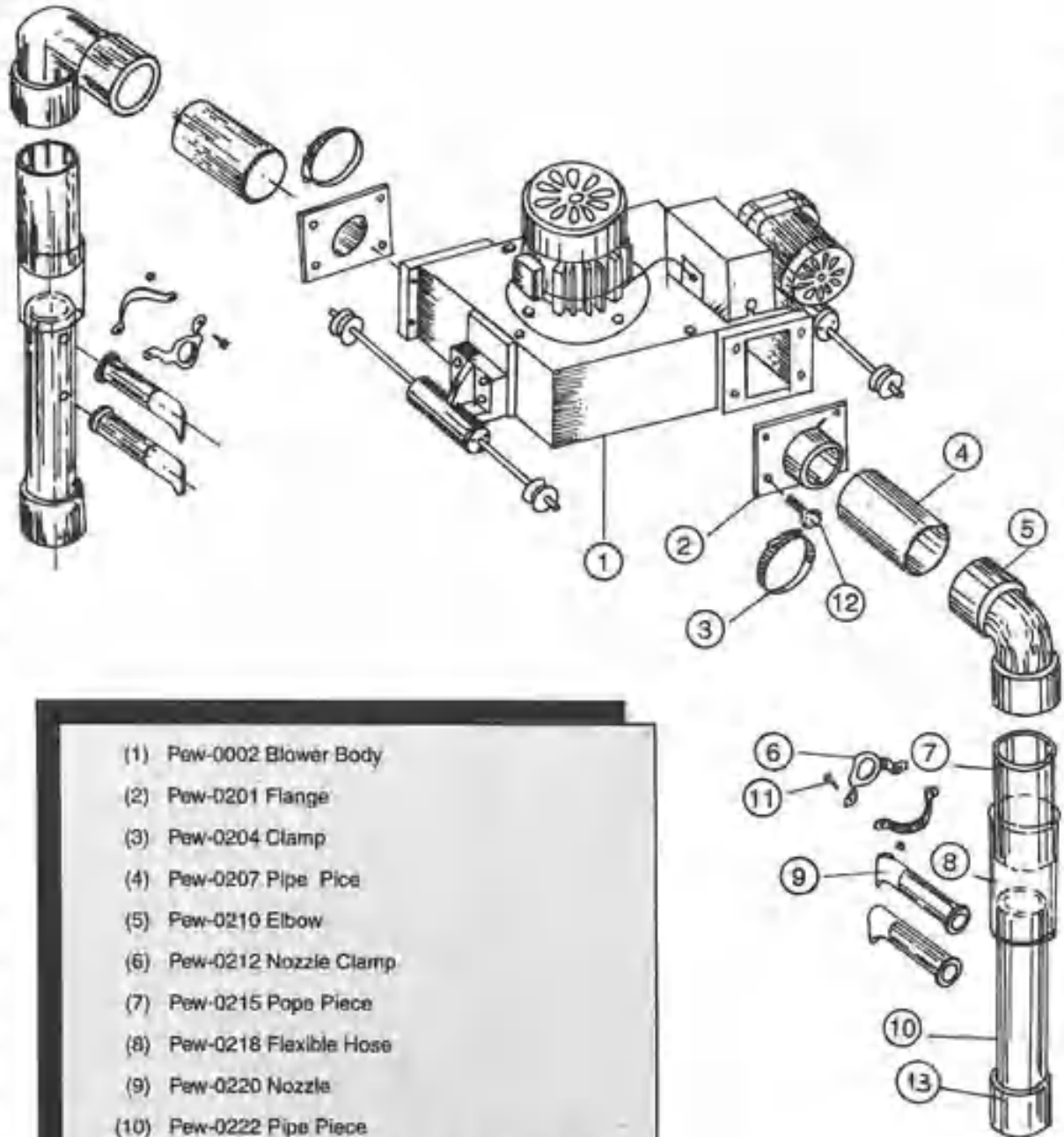

- (1) Pw-0002 Blower Body
- (2) Pw-0201 Flange
- (3) Pw-0204 Clamp
- (4) Pw-0207 Pipe Piece
- (5) Pw-0210 Elbow
- (6) Pw-0212 Nozzle Clamp
- (7) Pw-0215 Pipe Piece
- (8) Pw-0218 Flexible Hose
- (9) Pw-0220 Nozzle
- (10) Pw-0222 Pipe Piece
- (11) Pw-0224 Hex Pin with Plain Washer and Nut
- (12) Pw-0226 Hex Pin with Washer
- (13) Pw-0230 End Cap

RJK

FAN ASSEMBLY

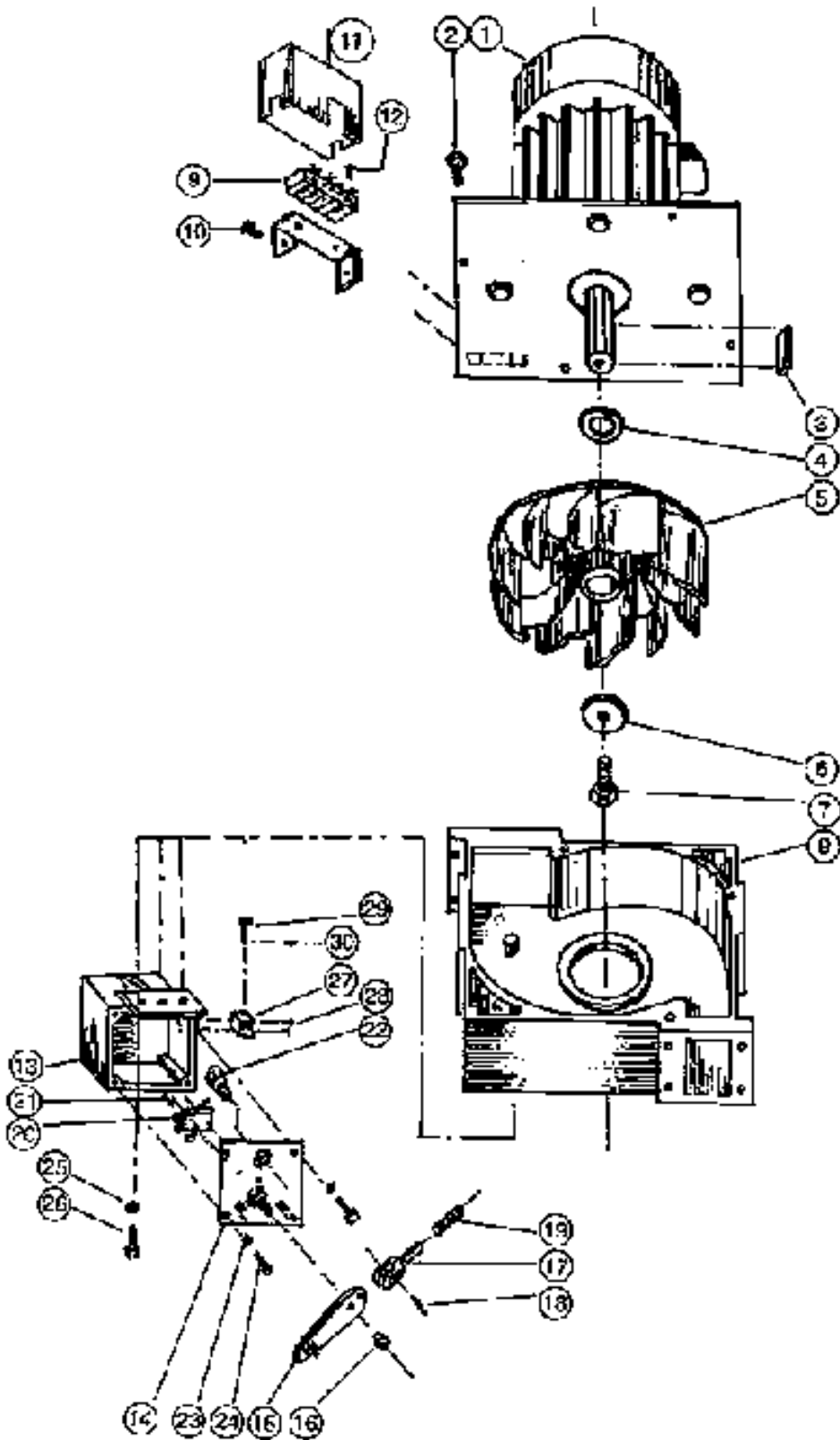

- (1) Pew-014 Blower Motor 110V
- (2) Pew-0018 Hex Pin
- (3) Pew-0016 Key
- (4) Pew-017 Spacer
- (5) Pew-0021 Fan
- (6) Pew-0019 Washer
- (7) Pew-023 Hex Pin
- (8) Pew-0002 Blower Body
- (9) Pew-024 Connection Strip
- (10) Pew-027 Screw
- (11) Pew-029 Relay Cover
- (12) Pew-031 Screw
- (13) Pew-033 Switch Box
- (14) Pew-037 R/F Switch Plate
- (15) Pew-039 R/F Lever
- (16) Pew-041 Stud with Nut
- (17) Pew-043 Pin
- (18) Pew-044 Slotted Pin
- (19) Pew-045 Spring
- (20) Pew-047 Micro Switch
- (21) Pew-049 Screw with Plain Washer & Nut
- (22) Pew-050 Cam Pin
- (23) Pew-053 spring Washer
- (24) Pew-054 Allen cap Screw
- (25) Pew-057 Spring Washer
- (26) Pew-058 Allen Cap Scuew
- (27) Pew-0162 Clamp
- (28) Pew-0163 Screw with Spring Washer
- (29) Pew-0164 Pin
- (30) Pew-0165 Cotter Pin

RJK

GEAR BOX ASSEMBLY

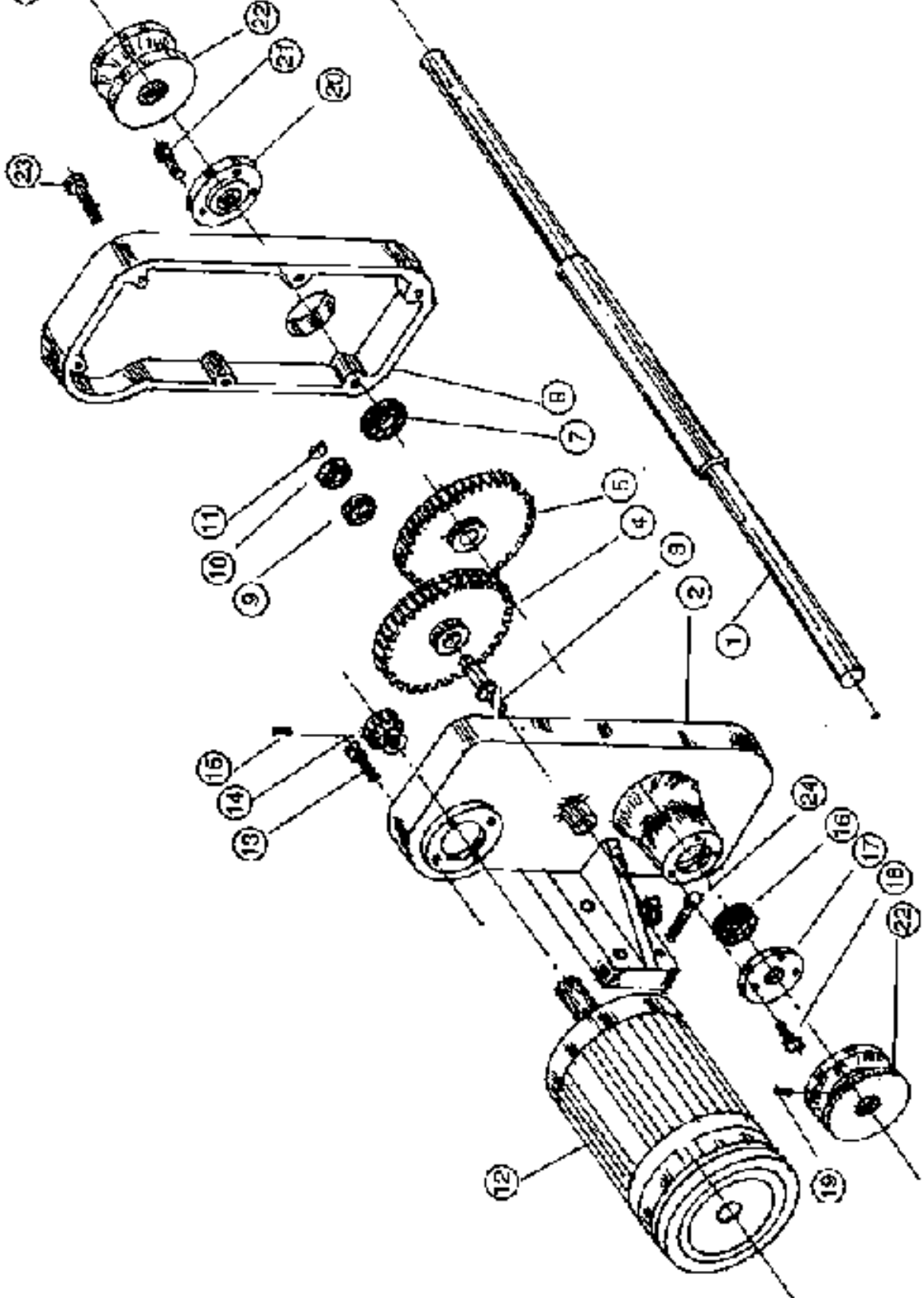

- (1) Pew-072 Gear Shaft
- (2) Pew-074 Gear Box Body
- (3) Pew-075 Bearing Pin
- (4) Pew-077 Gear with Bearing
- (5) Pew-079 Gear with Collar
- (7) Pew-083 Bearing 6004 ZZ
- (8) Pew-085 Gear Box Cover
- (9) Pew-088 Bearing NK 8112
- (10) Pew-088 Bearing NK 8112
- (11) Pew-089 Circlip
- (12) Pew-092 Gear Box Motor 110V
- (13) Pew-094 Allen Cap Screw
- (14) Pew-096 M.S. Gear
- (15) Pew-098 Dowel
- (16) Pew-083 Bearing 6004 ZZ
- (17) Pew-0101 Bearing Cover
- (18) Pew-0102 Screw
- (19) Pew-0104 Allen Grub Screw
- (20) Pew-0101 Bearing Cover
- (21) Pew-0102 Screw
- (22) Pew-0105 Wheel
- (23) Pew-0106 Allen Cap Screw with Spring Washer
- (24) Pew-0107 Hex Pin with Spring & Plain Washer



BRACKET ASSEMBLY

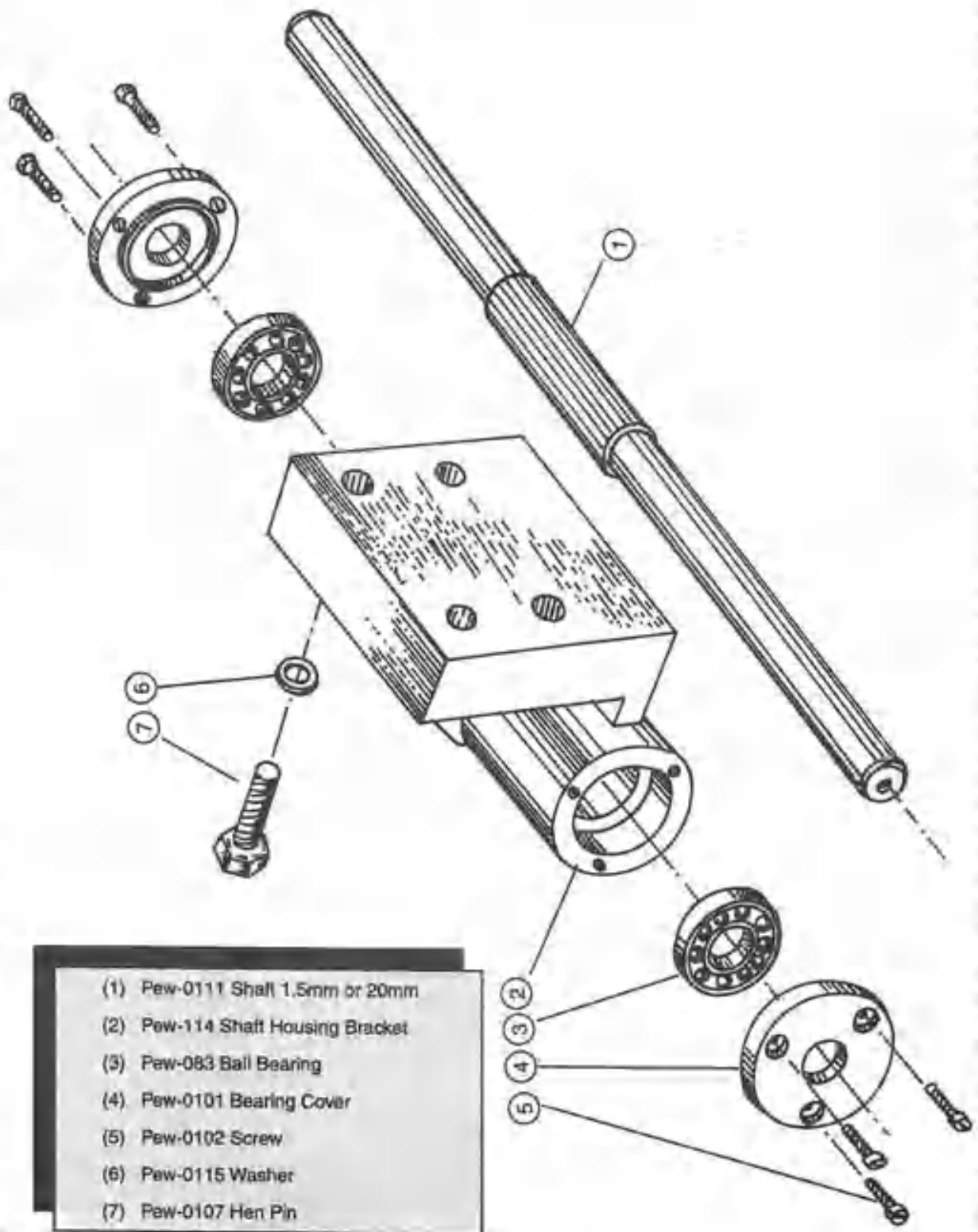

- (1) Few-0111 Shaft 1.5mm or 20mm
- (2) Few-114 Shaft Housing Bracket
- (3) Few-083 Ball Bearing
- (4) Few-0101 Bearing Cover
- (5) Few-0102 Screw
- (6) Few-0115 Washer
- (7) Few-0107 Hen Pin

FOOT BRAEKET ASSEMBLY - 1

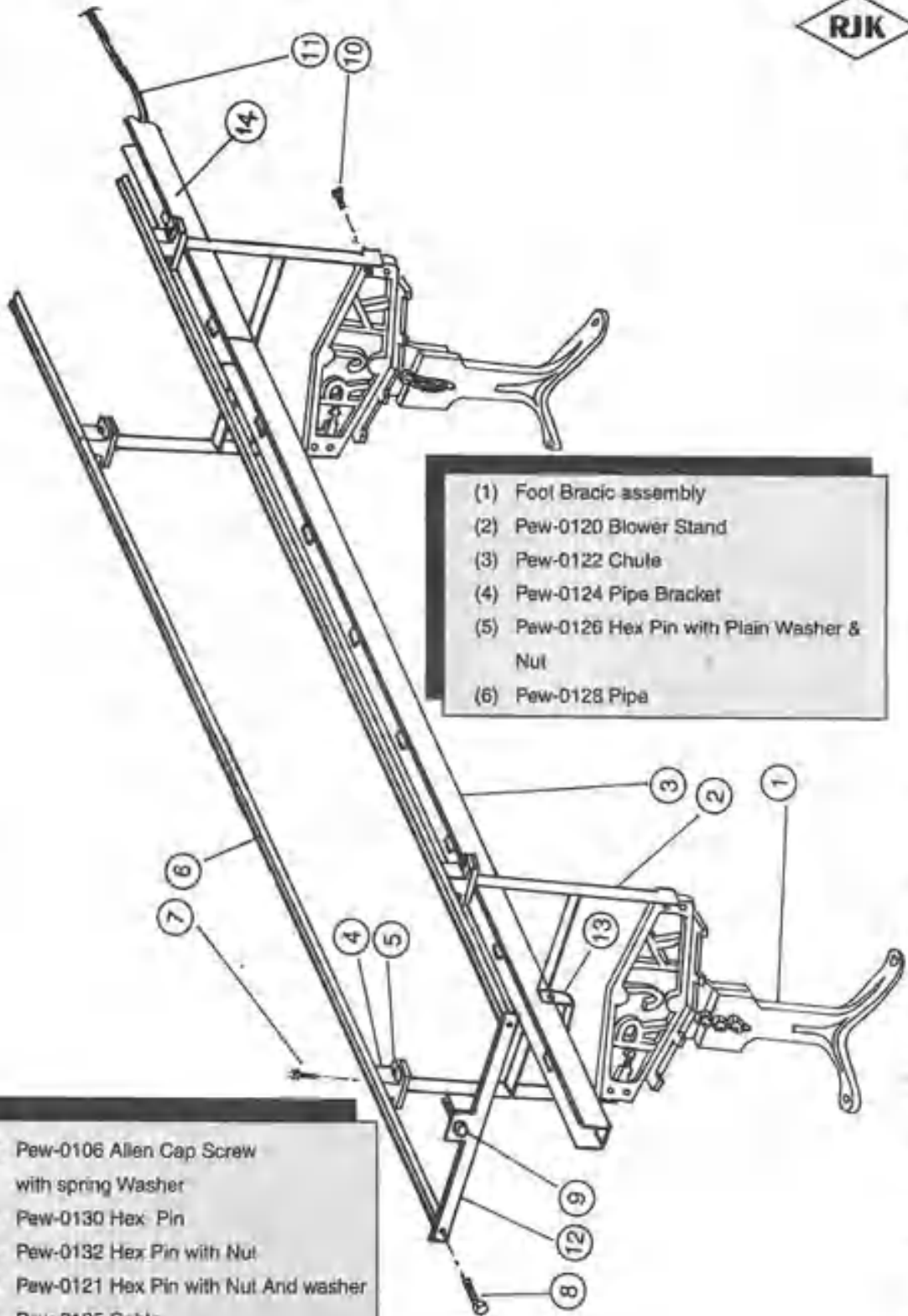

- (1) Foot Bracic assembly
- (2) Pew-0120 Blower Stand
- (3) Pew-0122 Chule
- (4) Pew-0124 Pipe Bracket
- (5) Pew-0126 Hex Pin with Plain Washer & Nut
- (6) Pew-0128 Pipe

- (7) Pew-0106 Allen Cap Screw with spring Washer
- (8) Pew-0130 Hex Pin
- (9) Pew-0132 Hex Pin with Nut
- (10) Pew-0121 Hex Pin with Nut And washer
- (11) Pew-0135 Cable
- (12) Pew-0141 End Piece
- (13) Pew-0147 Reverse Forward
- (14) Pew-0151 Chule

RJK

FOOT BRACKET ASSEMBLY NO. 2

- (1) Foot Bracic assembly
- (2) Pew-0120 Blower Stand
- (3) Pew-0121 Hex Pin with Nut And Washer
- (4) Pew-0139 Chute
- (5) Pew-0134 Line (with or Blacics
- (16) Pew-0149 Chute

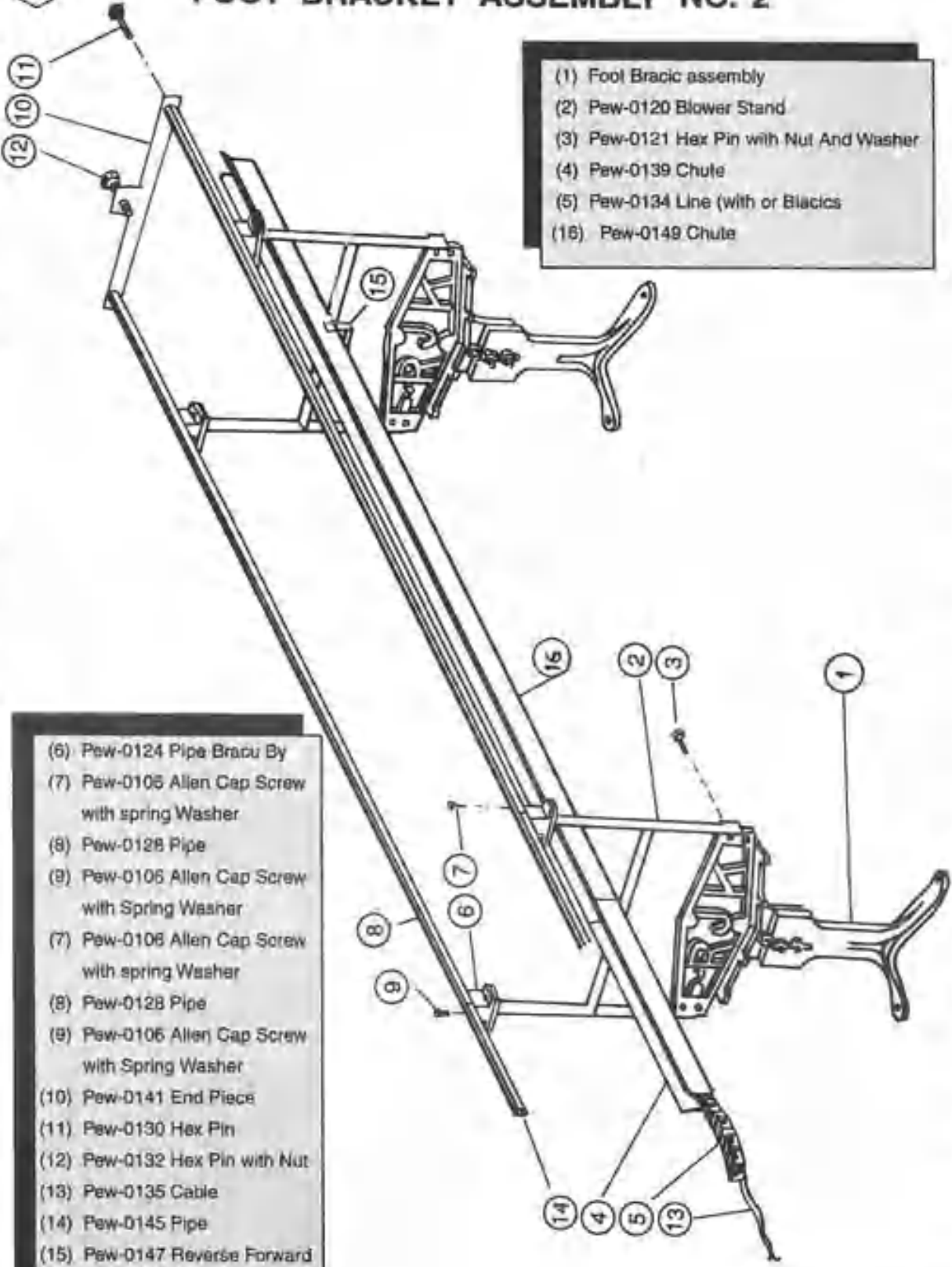

- (6) Pew-0124 Pipe Bracu By
- (7) Pew-0106 Allen Cap Screw with spring Washer
- (8) Pew-0128 Pipe
- (9) Pew-0106 Allen Cap Screw with Spring Washer
- (7) Pew-0106 Allen Cap Screw with spring Washer
- (8) Pew-0128 Pipe
- (9) Pew-0106 Allen Cap Screw with Spring Washer
- (10) Pew-0141 End Piece
- (11) Pew-0130 Hex Pin
- (12) Pew-0132 Hex Pin with Nut
- (13) Pew-0135 Cable
- (14) Pew-0145 Pipe
- (15) Pew-0147 Reverse Forward Stopper

TOOLS

RJK



1



2



3



4



5



6



7



8



9



10

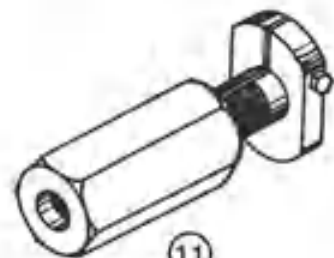

11



12

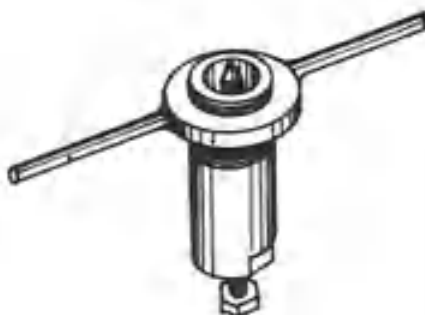

13

TOOLS

- (1) Long Screw Driver No. 028
- (2) Small Screw Driver No. 913
- (3) Small Screw Driver
- (4) Fixed Spanner Set 1/8" To 1/2" (12/6W)
- (5) Fixed Spanner 15/16" X 1"
- (6) Fixed Spanner 9 X 10
- (7) Slub Catcher Spanner
- (8) Gear Box Drum Shaft Spanner Big.
- (9) Gear Box Drum Shaft Spanner Small.
- (10) Allen Key Set
- (11) Drum Puller
- (12) Spanner For Paper Cone Adapter Nut
- (13) Spanner For Paper Cone Adapter
(For Holding)

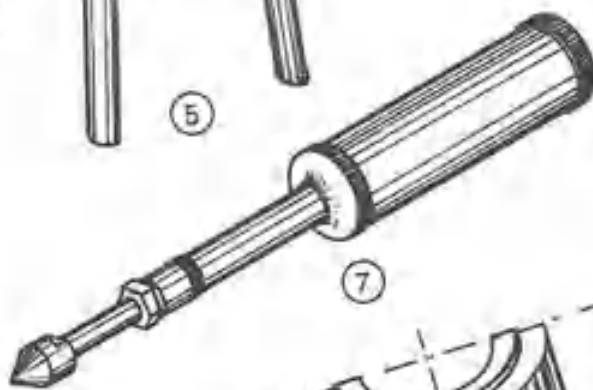
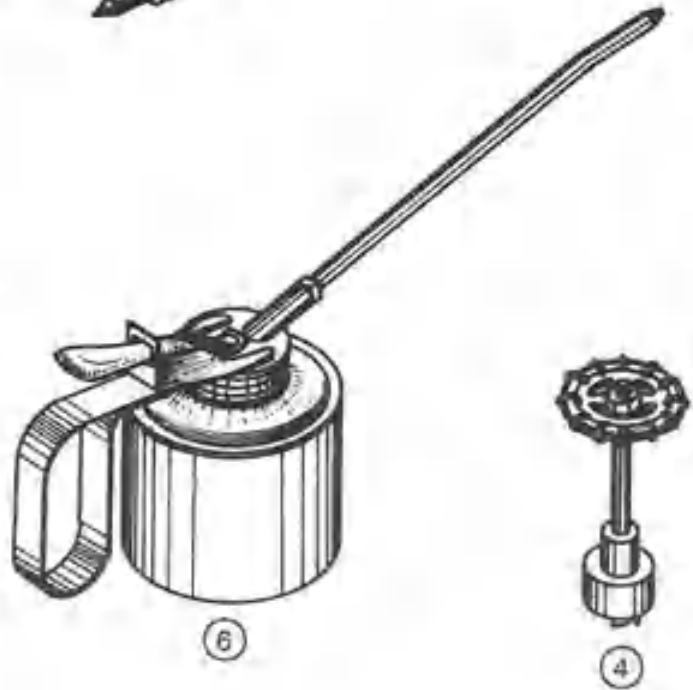
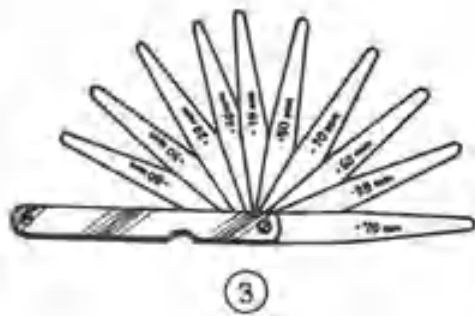
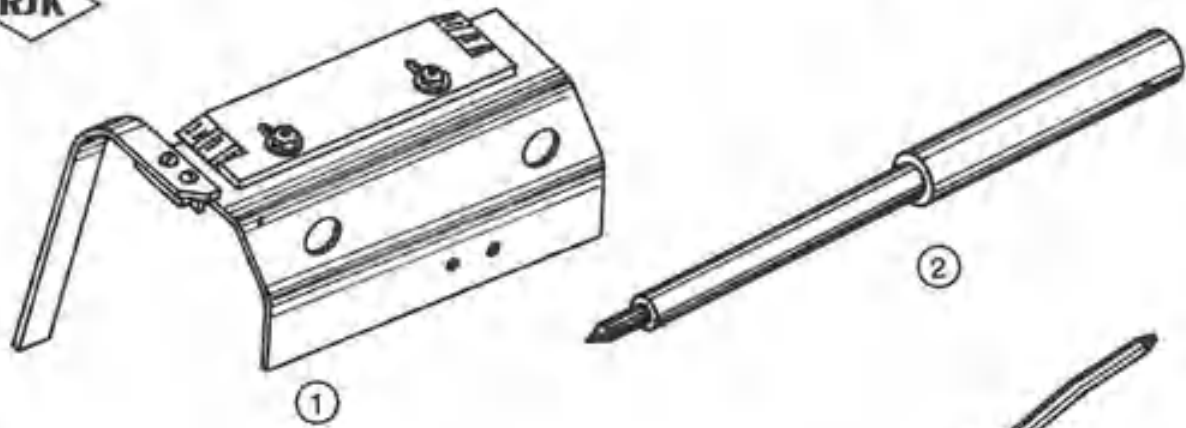

TOOLS

- (1) Cone Setting Gauge
- (2) Bobbin Setting Gauge
- (3) Feeler Gauge
- (4) Setting Gauge For ATIRA Slub Catcher
- (5) Stand For ATIRA Slub Catcher
- (6) Oil Can
- (7) Grease Gun
- (8) Grease Nipple For Bearing 6205 ZZ

CONE WINDING MACHINE

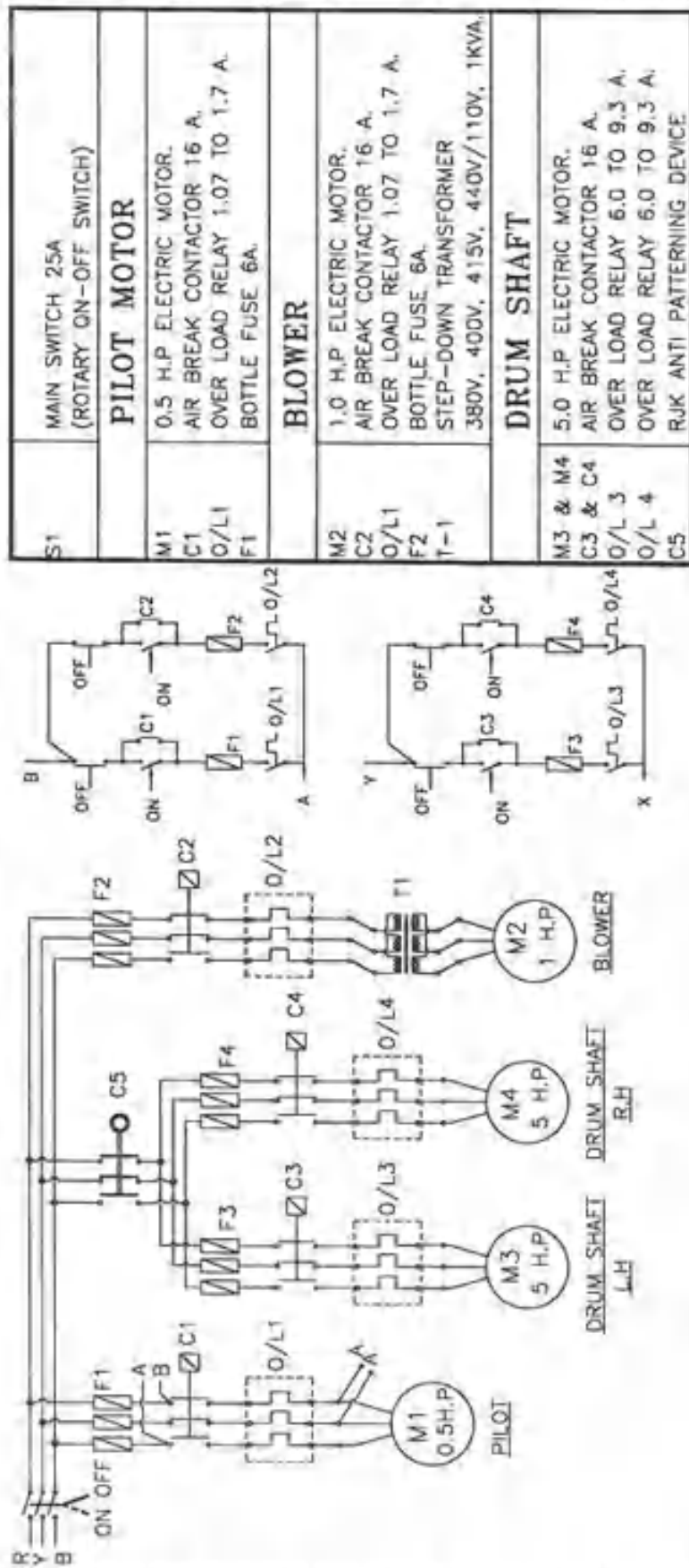

ELECTRICAL DIAGRAM



RJK

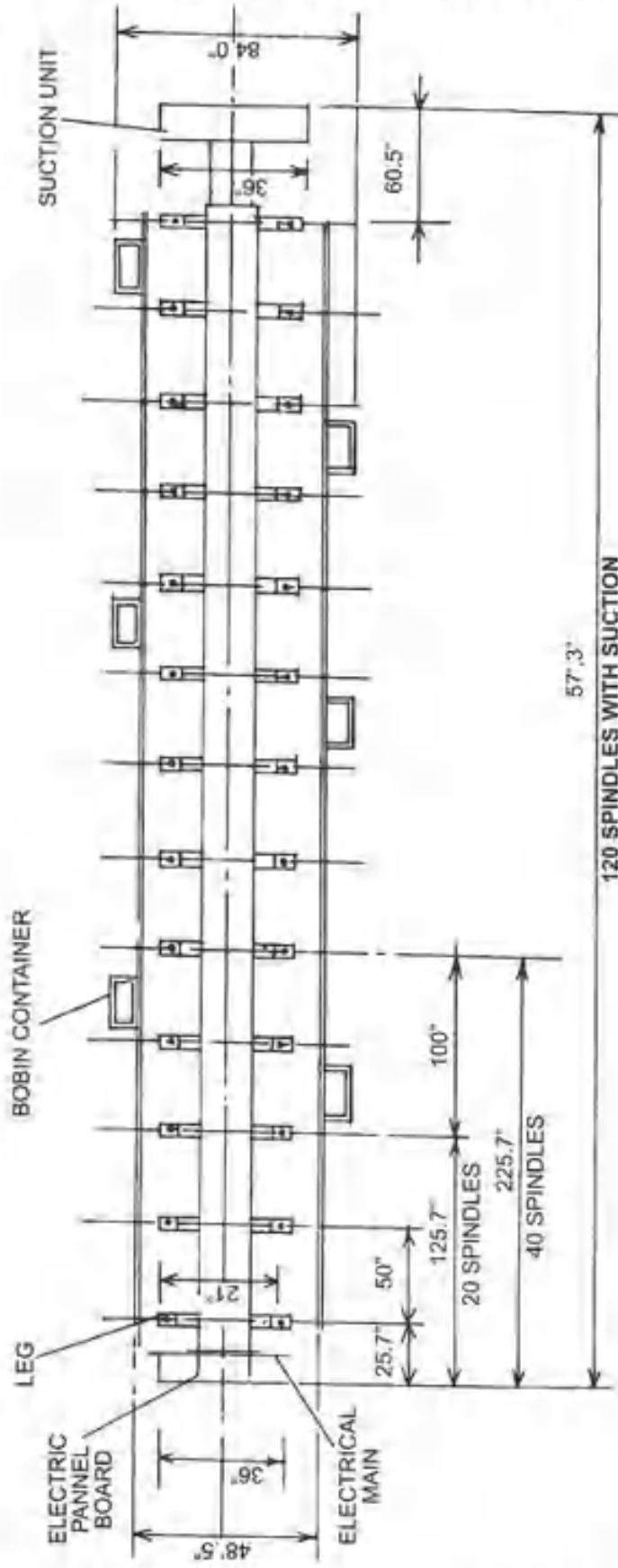

FOOT PRINT OF RJK CONE WINDING MACHINE

LENGTH OF MACHINE	57'-3"	WITH SUCTION
LENGTH OF MACHINE	53'-0"	WITH OUT SUCTION
HEIGHT OF MACHINE	7'-7"	WITH BLOWER
HEIGHT OF MACHINE	5'-1"	WITH OUT BLOWER
WIDTH OF MACHINE	84"	WITH TROLLY
WIDTH OF MACHINE	49"	WITHOUT TROLLY

POWER REQUIRED FOR MACHINE 14 H.P.

KINARIVALA R.J.K. INDUSTRIES
AHMEDABAD

INSTALLATION AND COMMISSIONING OF RJK HIGH SPEED CONE WINDING MACHINE

1. Place all the wooden cases alongside the line of installation in such a way that case no. / 1 is at the end of from where you wish to provide the drive to the Machine, C/S No. 1 contains electric panel, drive shaft motors. Please ensure that the arrows on all the cases point to this drive end.
2. Open CS No. 1 and place the panel & Gear box assembly on the centre line.
3. Open C/S No. 2 and place LEG No. 1 & 3 as per the foundation drawing, leaving out LEG No. 2 for time being (Use hex bolts 1/2" Dia 1.1/2" long with washers)
4. Put cut pieces of flannel 1/4" thick (compressed felt) between the LEG and the flooring if foundation has not been done. These have been sent alongwith the Machine. Also put Flannel PCS. below base.
5. Put the Channel of C/S No.2 on the two legs ensuring that the drive end of the channel rests on the base (71-110=28x) part No. B on page No. 4 & 5)
6. Open C/S No. 3 and place LEG No. 5 as per the foundation Drawing.
7. Place channel No. 2 resting it on LEG No. 3 at one end & LEG No. 5 at the other end. Again tightening LEG. No. 3 with channel No. 2, as before.
8. Continue this way until all the six channels are placed on the odd numbered legs.
9. Now place all the even numbered legs in their respective position and fix them onto the channels by bolting.
10. Note and check that all the even numbers legs are so far fixed only to the channels and not to the floor.
11. Tie a good quality non stretch string between the 2 ends of the machine on the centre line of the foundation. This string is very important as it is going to help in checking and getting the in line of the machine
12. Now observe adjust and match the marking line on the leg with that on the bottom of the channel and than tighten the Leg No. 1.
13. Adjust 1st leg in such way that washers at both the side between base plate and channel plate become tight. Ensure that LEG is also touched to the floor and not loose and cross levelling of machine is O.K.
14. Hang a pendulam from whole given in centre line at panel board side of channel (as shown in drawing) and match the string and pendulam in line. If it is not in line, adjust the string or LEG & panel board so that pendulam and string match to each other.
15. Check cross level again.
16. Go to LEG No. 3 match the marking of channel and LEG and tighten the LEG. hang the pendulam in centre line of channel. Match the string with pendulam. Simultaneously check the cross level and straight level with level bottle. Ensure that cross and straight level is perfect as well as string & pendulam are in line. Once again go to LEG No. 1 and check that there is no major changes in level also string & pendulam. If it is disturbed, set right.
17. Set the marking of channel to that on LEG. No. 2 and tighten the LEG. check cross and straight level near LEG. No. 2. Repeat the procedure as per Sr. No. 15 to ensure the perfection of level and machine is in line.
18. After completion of levelling and in line of 1st channel, join channel No. 2 (C/S No.3) with channel No. 1. Match the finished portion of upper side of both the channel. Tighten the LEG. go to LEG No. 5. Match the marking given on LEG No. 5 and channel. Tighten the LEG with channel No. 2. Repeat the procedure for levelling of machine and in line described in Sr. No. 15. After completion of
19. Repeat the procedures for leveling and in line for balance channels. (C/S. No. 4, 5, 6, 7)

ASSEMBLY OF MACHINE

20. After the completion of levelling fix 2 pins (3/8" X 1.1/2") with panel board end channel.
21. Open frame cap of all joints. Tighten all square cam.
22. Tighten all drum shaft couplings No. 2, 3, 4, 5, 6 on right side of machine by matching the markings and similarly coupling Nos. 22, 33, 44, 55, 66 on left side of machine.
23. Fix Juk stud block round and friction plate and tighten stud nutler on every joints.
24. Check that all oil pipes are connected with oil connection under the frame.
25. Fix RJK foot bracket numberwise on frame of each LEG of machine.
26. Assemble partition, lower supply shelf F.H. & lower supply shelf L.H. (Numberwise as described in drawing).
27. Fix it on RJK foot bracket one by one with stopping rod and switch lever all together. Be sure that No. 1, 2, 3, 4 etc. should be on R.H. side and No. 1 bar, 3 bar etc.

SETTING OF RIBBON BREAKER ASSEMBLY

28. Fix nylon round circle with screw on threads provided on nylon steel ribbon breaker compartment of panel board. Make hole big if hole does not match.
29. Check the gap between silver tipped contacts. Open contacts fully by rotating cam by hand. Keep 0.080" gap between two contact. Make sure that contactor is free while pressing contactor in, up and down direction.

PNEUMAFIL UNDER CLEANERS

30. Put Aluminum ducting between the legs with each other numberwise.
31. Connect last ducting with pneumafil filter box.
32. Keep sufficient gap between last leg and filter box for keeping empty bobbin collection box. Ensure that one side of first ducting, at panel board end, is covered.
33. Fix 3 pcs. tie rods between every LEG. do not overtighten rod. Overtight may disturb leveling of machine.

FIXING OF OIL PUMP ASSEMBLY

34. Fix remote end with LEG No. 13 and with last channel.
35. Loose eccentric collar. Fix pin on eccentric collar through ball bearing of 5/8 skewed bracket.
36. Rotate eccentric collar by hand for alignment. Tighten eccentric collar.
37. Fix oil pump tank inside of last leg of machine.
38. Connect plastic pipe with inlet and outlet connection of the oil tank.

BLOWER

39. Fix blower stand number wise on each RJK foot bracket.
40. Fix longer chute having welded bracket on 1st and 2nd blower stand and balance chutes having welded brackets upto spindle No. 30.
41. Fix plain chute from spindle No. 30 to 55 and longer one at last.
42. Fix longer blower pipes (PCS. 4) at both end of machine and balance pipes between big pipes on blower stand.
43. Put blower on blower pipes. Make connection of blower cable with blower terminal box and in panel board as per wiring diagram.
44. Ensure that nylon bracket chain should be towards remote end side of machine and cable is not twisted, otherwise there are chances of puncture of cable.
45. Fix end flat of blower on both ends of long pipes.
46. Check the direction of blower fan.

ASSEMBLY OF TROLLEY, CHAIN HOUSING, TENSION BRACKET

47. Remove conveyor housing cover. Remove key from gear box shaft. Fix conveyor housing.
48. Match the key hole with sprocket wheel. Fix key in gear box shaft.
49. Tighten the conveyor bolt with channel.
50. For proper alignment of two sprocket wheels, after starting of pilot motor for a short while, tighten alien screw provided on sprocket wheel of conveyor shaft.
51. Fix conveyor sheet number wise 1, 2, 3, 4, ... on R.H. side & No. 1 bar, 2 bar, 3 bar ... on L.H. side of bracket fixed on legs.
52. Fix conveyor belt guard.
53. Take conveyor belt from chain housing. Joint conveyor belt with belt joining clip. Pull conveyor belt with help of rod on remote end side and overlap it on remote end pulley.
54. Fix tension flat on R.H. bracket and L.H. bracket fixed on LEG. Assemble tension bracket with slub catchers. Fix it on tension flats.
55. Connect flexible pipe with slub catchers and rubber knobs fixed on ducting. Through clamp of conveyor guard.
56. Fix dead weight on spindle holder. (For hard package machine.)
57. Assemble MDP 112/113 combined bracket in 1" dia. shaft (Numberwise)
58. Fix above assembly (Number wise 1, 2, 3, ... on R.H. side and 1 bar, 2 bar, 3 bar, ... on L.H. side of machine) on legs.
59. Fix supply shaft of 15 MM dia. with robbin holder (Number wise 1, 2, 3, ... on R.H. side and 1 bar, 2 bar, 3 bar ...) on L.H. side of machine on supply bracket. This will damage bearings and electric motor.
60. Set supply spindle with robin setting rod.
61. Fix trolley sheet (numberwise 1, 2, 3, ... on R.H. side and 1 bar, 2 bar, 3 bar, ... on L.H. side of machine) on supply bracket. Match the joint of trolley sheet for smooth running of trolley.
62. Insert trolley pcs. 3 on each side after opening trolley sheet on each both side. Put box on trolley.
63. Put 0.5 liter oil in alternative frame of machine. Fill oil tank full of oil. Fill oil in gear box upto mark.
64. Give electric power of 440 V, 3 phase with earthing to main terminal box. Switch on on-off switch. Switch on pilot motor. Check the clock wise direction of pilot motor.
65. Fix 'V' belt on both side of drum shaft. Adjust tension of 'V' belt. Do not overtight 'V' belt.
66. Connect push button station knob with connection on panel board. Switch on drum shaft push button switch. Check anti-clock wise direction of drum shaft on R.H. side and clock wise direction on L.H. side.
67. Switch on blower's on-off switch. Check the direction of rotation of blower fan. Check function of reverse forward switch.
68. A separate starter is given for pneumafil under clearer.
69. Switch on pneumafil under cleare's on-off swith. Check the direction of rotation of blower fan.
70. Check the alignment of cone/cheese.
71. Set breakage wire for stop motion.
72. Lubricate the machine thoroughly wherever oil points are given.
73. Clean drums with petrol.
74. The above method for erection and commissioning of RJK high speed cone winding machine is for 120 spindles with a section of six channels. However, the same method is to be adopted for any No. of spindles. For any section.

MAINTENANCE OF RJK WINDING MACHINE

(1) CLEANING :

Always keep machine absolutely clean. A clean machine performs better & shows higher efficiency.

- (i) Remove, every day, fluff accumulation by blowing compressed, dry air on the machine. Fluff tends to accumulate especially at places like the Brush at the back of Bakelite Drum, on the Bearing Assembly & Spindle Holder, under Bearing Cap on cover of 5 H.P. Motor, Blower motor etc.
- (ii) After oiling remove all traces of excess oil remaining on surface of machine. This oil will otherwise attract & accumulate fluff.
- (iii) In case of AT RA Sub-Catcher with Suction Unit (Pneumatic Under clearers) open the vents (holes) of the suction box & remove any fluff accumulated inside, every 8 hrs. Also clean fluff accumulation on AT HA Tension Device.

CHECKING (MECHANICAL)

FOR BETTER WINDING ENSURE THAT :

- (1) There is no play in Bearing Assembly or that its holes are not worn out.
- (2) There are no cuts formed on Bakelite Drums. Never use a Knife to remove yarn wound to Drum. Use only special scissors meant for this.
- (3) Tension Discs rotate freely & all the time. If they are found to rotate slowly, remove fluff ring accumulation from the Flannel Washer.
- (4) Bearing Caps (7: -514 Sr. 17), which are to be opened only if absolutely necessary, are properly tightened when replaced.
- (5) V-Belts (B-58, Sr. 17) are sufficiently but not over-tightened.
- (6) The paper cones used for winding are of correct design, angle & dimensions. Avoid over used/worn-out cones.

ELECTRICAL CHECKING

THIS MAY BE CARRIED OUT EVERY WEEK AS UNDER :

(1) CHECK THE INPUT VOLTAGE :

It should be between 400 to 440 volts. Low input voltage will damage the motors.

(2) REMOVE THE CAM :

That operates Ribbon Breaker Contactor (Make & Break). This will leave both the 5 HP Motors running directly on the mains supply. Check the output current in all 3 phases.

(3) IF THE 3 PHASES ARE BALANCED :

And show a normal current reading of 5 to 6 ampères then measure the starting torque on each motor with a clip-on meter. This torque should be 17 to 20 Amp (at 699 ypm) or 25 to 30 Amp (@ 800 ypm). If the torque is normal, the electrical system is in order.

(4) IF THE 3 PHASES ARE NOT BALANCED :

Or if any phase is weak, check whether :

- (i) The fuse connections are loose or if the fuse is blown off.
- (ii) Terminal wires of the mains supply in the Electrical panel are loose.
- (iii) Motor connections are loose.
- (iv) Air break Contactor or overload Relay connections are loose.
- (v) The gap between Upper & Lower (Fixed & Moving) Silver Tipped Contacts of the Ribbon Breaker assembly needs resetting. This gap should be maintained at 0.080". Resetting can be done using Feeler Gauge supplied along with machine.

(5) IF THE 3 PHASES ARE BALANCED BUT :

Show a current reading higher than normal, disconnect the motors from the Traverse (Drum) Shaft by Removing the V-Belt & recheck the current in all 3 phases.

If the current reading is now normal it implies that the high current reading may have been due to overload on Drum Shaft. >> Go to step (6)

On the contrary if the current reading is still high then the fault could lie with motor >>> Go to step (7).

(6) FOR OVERLOAD ON DRUM SHAFT CHECK IF :

- (i) Yarn is wound on Drum Shaft. Remove it.
- (ii) Bearing Caps have been over tightened.
- (iii) Anti-Warp Brushes are held too tightly on to the Drums.
- (iv) Ball-Bearings are jammed/damaged.
- (v) Paper Cone Holders are not freely rotating.

(7) FOR SUSTAINED HIGH CURRENT READING :

Remove V-Belt to unload the motor & check motor Ball-Bearings. Replace if necessary. Check the input voltage on the motor connection box. In case of 1/2 HP Gear Box motor check also the Gear Box Ball-Bearings. If the torque reading is still high check the gap between the Fixed & Moving Silver contacts, which should be 0.080".

If the Drum Shaft RPM falls more than 10% Then readjust the position of the Steel Cam pieces. (i.e. The Drum Shaft Shaft running at 3000 RPM should not run at less than 2700 RPM). In such a case bring the two Steel Cam pieces closer.)

OILING

(1) GEAR-BOX ASSEMBLY :

Maintain oil level at the maximum indication mark provided on the glass dial. Change oil after the first 3 months & then every 6 months. No greasing necessary on Ball-bearings 6207 ZZ & 6205 ZZ. The Gear-Box oiling system is independent from that of the Main Boxes (Frames). Pour oil through the oil plug provided.

(2) CONVEYOR :

Open the Chain Wheel Cover (71-259-3, Sr. 12) & grease the Sprocket Wheels (Sr. 9) every 3 months.

(3) BALL-BEARINGS :

Ball-bearings (6205 ZZ) on Drum Shaft (71-643 Inverse Shaft, Sr. 2 & 3) are double sealed. Hence, ordinarily no oiling or greasing required. If necessary greasing may be done using the special Grease Nipple provided along with the machine.

(4) BEARING ASSEMBLY (71-43-15X, Sr. 4) :

Oil daily through the three Press-Button Oilers.

(5) SPINDLE HOLDER (71-41-18, Sr. 1) :

Oil through the hole on the Spindle Holder Oil pin (71-682 Stud, Sr. 4).

(6) PAPER CONE HOLDER ASSEMBLY :

Remove any yarn accumulation. No greasing is necessary as the two Ball Bearings used inside are double-sealed (6000 77).

(7) MAIN BOX (FRAME) :

Oil daily the three Press-Buttons on the Frame Cap and the Frame Cover.

(8) MOTORS :

Grease as recommended by motor manufacturers.

(9) M & B Contactors :

Oil and Grease using special lubricant, once a month, all the moving parts such as Stubs where oil holes are provided.

(10) Oil Tank :

Pour oil whenever the oil level falls.

(11) Oil Circulating pump :

This unique pump is being supplied as a standard equipment with all the machines from 1979.

MISCELLANEOUS NOTES :

(i) 1/2 H.P. Pilot Motor :

This runs the Centre - Shaft at 30/32 RPM & operates the stop-motion system. It is provided with a contactor, an over-load relay and HRC fuse. Attached to it is the Cam which operates the make & Break Contactor 32 times a minute.

(ii) Make & Break Contactor (Ribbon Breaker Assembly) :

This unique, RJK designed Contactor with silver tipped contacts stops the 5 H.P. Motors (8 thereby the drumshafts) 30 to 32 times in a minute for a fraction of a second. This prevents formation of nobs in winding.

Never use a file or a sand-paper to clean the silver tips. They must always be wiped clean with a smooth cloth. Also never use oil or grease on same. Always maintain the gap between the upper & lower contacts at 0.080".

(iii) Protection of motors from overloading :

Fuses/Relays have been provided wherever possible to protect the motors. If a motor starts on two phase the O/L relay will trip and stop the motor. Or, if a running motor jams up suddenly and O/L relay fails to function, the fuse will blow off and save the motor. The O/L relay must always be set at the correct value to make sure that it functions properly.

LUBRICATION CHART

(1) WHEN INSTALLING MACHINE :

Initially, when installing / commissioning the machine remove / open the second, the sixth & then every fifth Frame Cap (i.e. 2nd, 6th, 11th, 16th, 21st.....)

Now pour about 1.25 ltr. of oil into the Gear Box Assembly by opening the Oil Plug provided on top of the Pilot Motor Rest.

THE OIL TO BE USED : SAE 40 OR EQUIVALENT GOOD QUALITY OIL

(2) FRAME (BIG BOX) :

Oil daily the Press Button Oiler provided on Frame Cover.

(3) ELECTRIC MOTORS :

Grease as recommended by motor manufactures.

(4) RIBBON BREAKER ASSEMBLY (MAKE & BREAK CONTACTOR) :

Put a little grease on top of Cam Bearing (Sr. 12) Also put some grease on top of Guide Collar for 1/2" dia M.S. Stud (Sr. 7)



(5) OIL TANK :

Fill up with oil whenever the level falls as this oil is slowly transferred to the Frames by the Oil Circulating Pump Assembly.

(6) OIL CIRCULATING PUMP :

This unique pump is being supplied as a standard equipment with all machines. Periodically it may be checked. Observe through the glass dial the continuous flow of oil.

WHAT TO CHECK FIRST IN CASE OF TROUBLE.

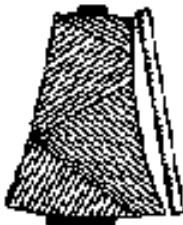
FAULT	POSSIBLE CAUSES.	REMEDY
STICHES 	(1) Cone Holder incorrectly set	Use Cone Setting Gauge 71-245 CAX. Reset.
	(2) Yarn jumping from groove near end of traverse.	Move Tension Bracket (71A-11, Sr. 13) towards end where stiches occur.
	(3) Yarn Waste wrapped around base	Remove yarn waste so cone Holder will rotate freely.
	(4) Tension Discs held open by lint or slubs.	Clean between Discs.
	(5) Fluff in Buikfor Cam Half Round Bracket	Remove fluff
	(6) Breakage Lever Vibration.	Reset with help of Adjusting Clamps.
BULGING 	(1) Too much pressure on base of Cone causing nose to lift up.	Check Cone Holder setting with Cone Setting Gauge 71-245 CAX Reset if necessary.
	(2) Loss of tension on yarn.	Look for & remove lint buttons between Tension Discs or glazed disc.
BELL-SHAPED PACKAGE 	(1) Too much tension on yarn.	Reduce tension weight.
	(2) Cone Holder incorrectly	Reset with Cone Setting Gauge

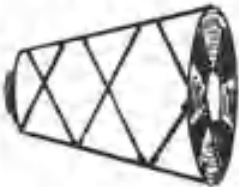
<p>EXCESSIVE END BREAKAGE</p> 	(1) Too many Tension Weights.	Reduce Tension Weights and if necessary balance Breakage Lever.
	(2) Supply Spindle out of line.	Line up Supply Spindle with eye of Tension Bracket (71-264-11, Sr, 13) Using Bobbing Setting Rod.
	(3) Yarn delivered from supply package drags over surface of supply package.	Move Supply Bobbin closer to Tension Bracket to widen ballooning of yarn.
	(4) Slub Catcher setting wrong.	Check for proper setting.
<p>RIBBON FORMATION</p> 	(1) Cone Holder incorrectly set.	Use Gauge for proper setting.
	(2) Contactor Cam Steel pieces setting wrong	Open or Close Steel CAM Pices (Sr. 14) of Ribbon Breaker Assembly.
	(3) Cone Holder not rotating freely	Remove waste and lubricate